

5
614.862
H3a
1957

ACCIDENT REPORT
ON MONTANA'S
RURAL PRIMARY HIGHWAY SYSTEM
1957

PREPARED BY THE
MONTANA STATE HIGHWAY COMMISSION
PLANNING SURVEY DIVISION
IN COOPERATION WITH
U.S. DEPARTMENT OF COMMERCE
BUREAU OF PUBLIC ROADS

Montana State Library



3 0864 1006 4331 4

INTRODUCTION

This report presents 1957 traffic accident data on the rural sections of Montana's Primary Highway system. It is based on all accidents occurring on this system that were reported to the Highway Patrol during the year.

Details of all accidents resulting in twenty five dollars or more property damage, an injury or a death, must be submitted to the Montana Highway Patrol on standard report forms as required by State law. Data from each accident report were transferred to International Business Machine cards to facilitate summarization. Business Machine methods were also used to compute the accident rate and print the duplimats from which this report was reproduced.

The first section of the report lists pertinent accident data by Highway Patrol section on each Federal Aid route. The second section of the report lists each Highway Patrol section in descending order by accident rate per 1,000,000 vehicle miles.

The following tabulation is a State wide summary of each item listed in the report.

ITEM	STATE WIDE GRAND TOTAL
Section length in miles & tenths (Rural constructed mileage - Primary System)	5644.7
Average Daily Traffic Volume	788
Number of Property Damage Accidents	2969
Number of Injury Accidents	1070
Number of Fatal Accidents	118
Total Number of Accidents	4157

Number of persons injured	1716
Number of persons killed	143
Amount of property damage as reported to Highway Patrol	\$2,772,890
Total economic loss based on the National Safety Council's estimate of \$1,000 for each personal injury and \$22,000 for each fatality added to the reported property damage.	\$7,634,890
Accident rate - expressed as the total number of accidents of all types per million vehicle miles of travel.	2.6

The State map on the following page shows the location of all sections of highway having an accident rate above the State average of 2.6. About 325 miles of highway shown in red have an accident rate of from 5.0 to 38.1 and are considered critical. Sections shown in yellow, totaling 2163 miles, have an accident rate of from 2.6 to 4.9. Sections below the State average of 2.6 accidents per million vehicle miles of travel total 3157 miles and are shown on the map by means of an open band.

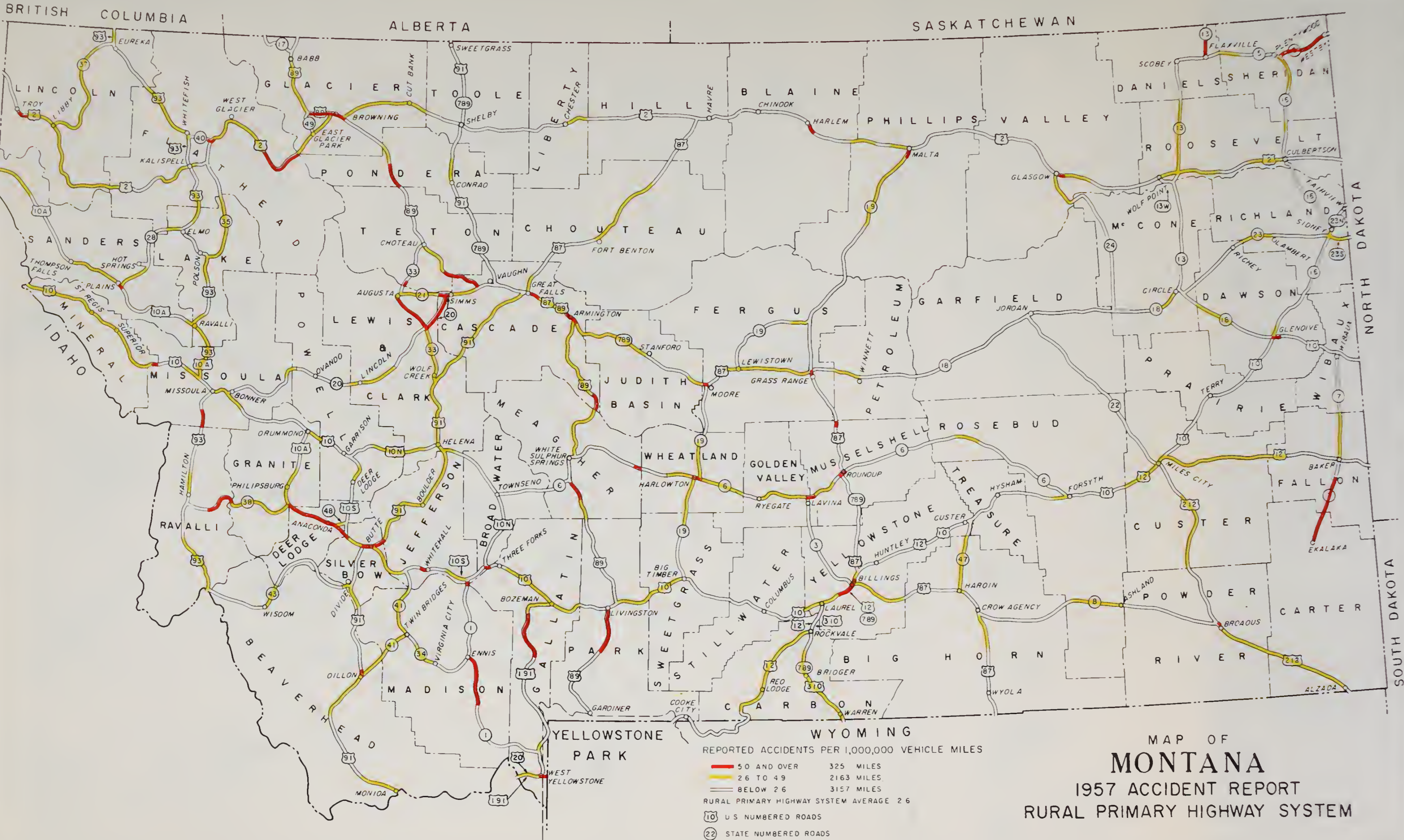

REPORTED ACCIDENTS PER 1,000,000 VEHICLE MILES

- 50 AND OVER 325 MILES
- 26 TO 49 2163 MILES
- BELOW 26 3157 MILES

RURAL PRIMARY HIGHWAY SYSTEM AVERAGE 2.6

10 U.S. NUMBERED ROADS

22 STATE NUMBERED ROADS

MAP OF
MONTANA
 1957 ACCIDENT REPORT
 RURAL PRIMARY HIGHWAY SYSTEM



Digitized by the Internet Archive
in 2014

http://archive.org/details/accidentreporto1957mont_0

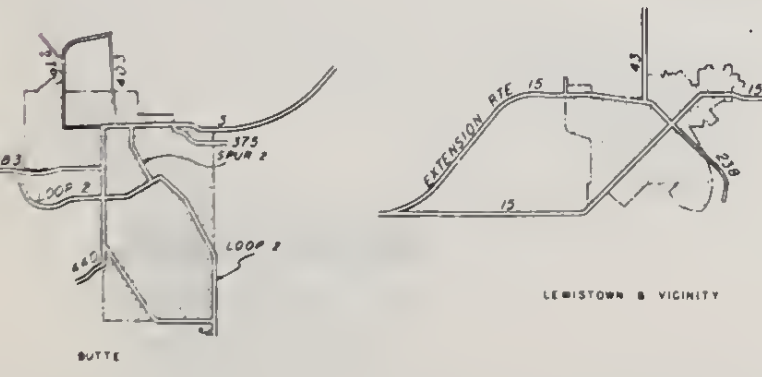
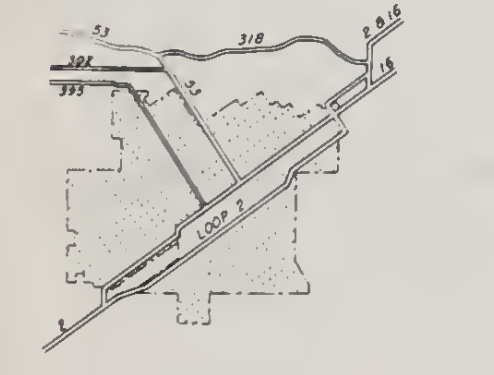
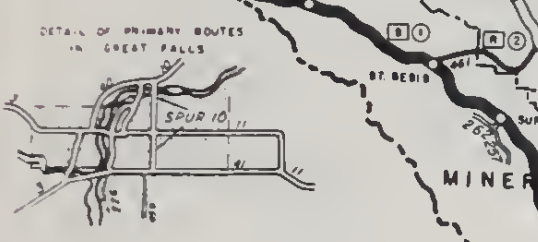
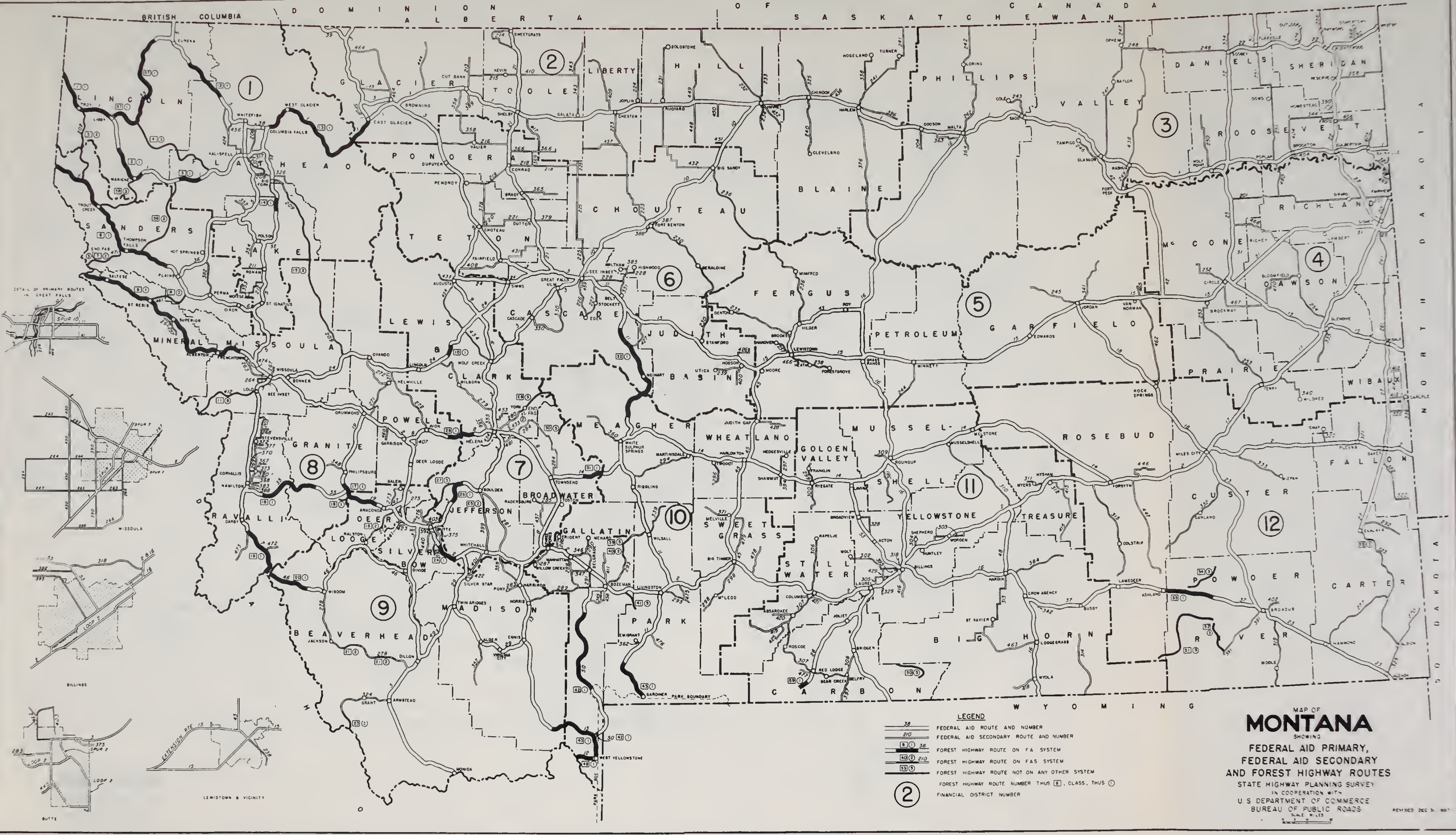

- LEGEND**
- FEDERAL AID ROUTE AND NUMBER
 - FEDERAL AID SECONDARY ROUTE AND NUMBER
 - FOREST HIGHWAY ROUTE ON FA SYSTEM
 - FOREST HIGHWAY ROUTE ON FAS SYSTEM
 - FOREST HIGHWAY ROUTE NOT ON ANY OTHER SYSTEM
 - FINANCIAL DISTRICT NUMBER

MAP OF
MONTANA
SHOWING
FEDERAL AID PRIMARY,
FEDERAL AID SECONDARY
AND FOREST HIGHWAY ROUTES
STATE HIGHWAY PLANNING SURVEY
IN COOPERATION WITH
U.S. DEPARTMENT OF COMMERCE
BUREAU OF PUBLIC ROADS
SCALE 1:125,000
REVISED DEC. 3, 1937



MAP OF
MONTANA
PREPARED BY
STATE HIGHWAY PLANNING SURVEY
IN COOPERATION WITH
U.S. DEPARTMENT OF COMMERCE
BUREAU OF PUBLIC ROADS
SCALE 1" = 50 MILES

ROUTE NO.	SECTION DESCRIPTION	SECTION LENGTH	AVERAGE DAILY TRAFFIC	NO. OF ACCIDENTS				NO. OF PEOPLE		AMOUNT OF PROPERTY DAMAGE	TOTAL ECONOMIC LOSS	ACCIDENT RATE
				PROPERTY DAMAGE	INJURY	FATAL	TOTAL ACCIDENT	INJURED	KILLED			
US 2	MONTANA-IDAHO LINE	13.9	726	5	1	2	8	4	2	8470	56470	2.2
US 2	TROY CITY LIMITS	.5	CITY									
US 2	TROY CITY LIMITS	2.5	988	3	2		5	2		2100	4100	5.5
US 2	FAS 202	15.3	1225	21	8	1	30	14	1	10880	46880	4.4
US 2	LIBBY CITY LIMITS	.9	CITY									
US 2	LIBBY CITY LIMITS	27.6	807	34	5	1	40	6	1	13830	41830	4.9
US 2	MANICKE JUNCTION	19.7	605	15	2		17	2		6520	8520	3.9
US 2	FLATHEAD COUNTY LINE	20.1	629	6	4	1	11	12	1	5350	39350	2.4
US 2	MARION JUNCTION	19.9	1004	18	8		26	8		11200	19200	3.6
US 2	KALISPELL CITY LIMITS	1.1	CITY									
US 2	KALISPELL CITY LIMITS	1.4	6300	9	5		14	8		10520	18520	4.3
US 2	FAS 206	5.4	2179	6	2		8	2		3870	5870	1.9
US 2	FAP 52-MONT. 35	10.1	1442	4	4	1	9	8	1	4390	34390	1.7
US 2	FAP 38-MONT. 40	14.9	1692	20	9	1	30	11	1	14000	47000	3.3
US 2	WEST GLACIER SPUR	27.8	499	13	5		18	6		10750	16750	3.6
US 2	GLACIER PARK BOUNDARY	16.8	479	12	3		15	4		4230	8230	5.1
US 2	GLACIER COUNTY LINE	11.3	553	7	1		8	1		4990	5990	3.5
US 2	EAST GLACIER SPUR	11.3	711	10	1		11	1		4050	5050	3.8
US 2	PTW NEAR BROWNING	1.3	NON	EX.								
US 2	FAP 3-US89	2.3	1740	8			8			3500	3500	5.5
US 2	FAP 3-US89											

ROUTE NO.	SECTION DESCRIPTION	SECTION LENGTH	AVERAGE DAILY TRAFFIC	NO. OF ACCIDENTS				NO. OF PEOPLE		AMOUNT OF PROPERTY DAMAGE	TOTAL ECONOMIC LOSS	ACCIDENT RATE
				PROPERTY DAMAGE	INJURY	FATAL	TOTAL ACCIDENT	INJURED	KILLED			
US 2	FAP 3-US89	30.7	961	38	7	1	46	10	1	20690	52690	4.3
US 2	CUT BANK CITY LIMITS	1.0	CITY									
US 2	CUT BANK CITY LIMITS	2.4	1643	6	1		7	1		2550	3550	4.9
US 2	FAS 389	5.1	1185	7	3		10	5		5070	10070	4.5
US 2	TOOLE COUNTY LINE	15.5	1155	14			14			6420	6420	2.1
US 2	SHELBY CITY LIMITS	1.3	CITY									
US 2	SHELBY CITY LIMITS	26.9	860	6	3	2	11	9	2	14190	67190	1.3
US 2	LIBERTY CO. LINE	12.8	812	3		2	5		2	4850	48850	1.3
US 2	FAS 409	2.0	1105				NONE					
US 2	CHESTER CITY LIMITS	.9	CITY									
US 2	CHESTER CITY LIMITS	9.2	832	8	1		9	1		2690	3690	3.2
US 2	FAS 224 NEAR JOPLIN	.8	785	1			1			400	400	4.4
US 2	HILL CO. LINE	9.3	872	1	1		2	2		3000	5000	.7
US 2	FAS 231	37.2	984	13	2	3	18	6	4	13600	107600	1.3
US 2	FAP 10-US87	2.5	2397	3			3			1570	1570	1.4
US 2	HAVRE CITY LIMITS	1.4	CITY									
US 2	HAVRE CITY LIMITS	8.0	1932	4	3	1	8	4	1	10180	36180	1.4
US 2	BLAINE CO. LINE	12.6	1548	6	4		10	6		12900	18900	1.4
US 2	CHINOOK CITY LIMITS	.5	CITY									
US 2	CHINOOK CITY LIMITS	.5	1836				NONE					
US 2	FAS 325											

ROUTE NO.	SECTION DESCRIPTION	SECTION LENGTH	AVERAGE DAILY TRAFFIC	NO. OF ACCIDENTS				NO. OF PEOPLE		AMOUNT OF PROPERTY DAMAGE	TOTAL ECONOMIC LOSS	ACCIDENT RATE
				PROPERTY DAMAGE	INJURY	FATAL	TOTAL ACCIDENT	INJURED	KILLED			
US 2	FAS 325	20.0	1168	12	3	1	16	5	1	7450	34450	1.9
US 2	HARLEM CITY LIMITS	.8	CITY									
US 2	HARLEM CITY LIMITS	.9	1291	4			4			2230	2230	9.4
US 2	FAS 396	20.1	775	10	3		13	6		11260	17260	2.3
US 2	PHILLIPS COUNTY LINE	7.4	691	4	3		7	5		4840	9840	3.8
US 2	DODSON CITY LIMITS	.8	CITY									
US 2	DODSON CITY LIMITS	8.1	885	1			1			150	150	.4
US 2	FAS 363	9.1	1108	10	3	1	14	4	1	5750	31750	3.8
US 2	MALTA CITY LIMITS	.9	CITY									
US 2	MALTA CITY LIMITS	26.9	843	8	8		16	10		12930	22930	1.9
US 2	SACO CITY LIMITS	.9	CITY									
US 2	SACO CITY LIMITS	1.5	865			1	1	2	2	1300	47300	2.1
US 2	VALLEY CO. LINE	40.5	955	16	10	1	27	15	1	18040	55040	1.9
US 2	GLASGOW CITY LIMITS	.5	CITY									
US 2	GLASGOW CITY LIMITS	1.4	2008	3	3		6	3		4400	7400	5.8
US 2	FAS 247	11.7	1134	14	5		19	8		9440	17440	3.9
US 2	NASHUA CITY LIMITS	.9	CITY									
US 2	NASHUA CITY LIMITS	25.2	939	14	4	1	19	9	1	11890	42890	2.2
US 2	ROOSEVELT CO. LINE	9.3	1171	7	2	1	10	14	1	8520	44520	2.5
US 2	WOLF POINT CITY LIMITS	.6	CITY									
US 2	WOLF POINT CITY LIMITS											

FAP NO 1

ROUTE NO.	SECTION DESCRIPTION	SECTION LENGTH	AVERAGE DAILY TRAFFIC	NO. OF ACCIDENTS				NO. OF PEOPLE		AMOUNT OF PROPERTY DAMAGE	TOTAL ECONOMIC LOSS	ACCIDENT RATE
				PROPERTY DAMAGE	INJURY	FATAL	TOTAL ACCIDENT	INJURED	KILLED			
US 2	WOLF POINT CITY LIMITS	6.2	1269	7	2		9	3	5580	8580	3.1	
US 2	FAP 32-MONT. 13	14.9	1155	12	4	1	17	6	6640	34640	2.7	
US 2	POPLAR CITY LIMITS	.4	CITY									
US 2	POPLAR CITY LIMITS	5.3	1189	6	2	1	9	3	4540	73540	3.9	
US 2	FAS 251	8.5	958	4			4		1890	1890	1.3	
US 2	BROCKTON CITY LIMITS	.5	CITY									
US 2	BROCKTON CITY LIMITS	18.1	737	12	3		15	6	10120	16120	3.1	
US 2	CULBERTSON CITY LIMITS	.8	CITY									
US 2	CULBERTSON CITY LIMITS	14.0	880	5	1	1	7	2	8300	54300	1.6	
US 2	FAS 327 NEAR BAINVILLE	8.2	767	3	1		4	1	3850	4850	1.7	
	MONT.-NORTH DAKOTA LINE											
	WEST GLACIER SPUR											
	FAP 1 NEAR WEST GLACIER	.3	690				NONE					
	GLACIER PARK BOUNDARY											
	EAST GLACIER SPUR											
MO 49	FAP 1 NEAR EAST GLACIER	11.9	211	1			1		300	300	1.1	
	FAP 3 NEAR KIOWA											

ROUTE NO.	SECTION DESCRIPTION	SECTION LENGTH	AVERAGE DAILY TRAFFIC	NO. OF ACCIDENTS				NO. OF PEOPLE		AMOUNT OF PROPERTY DAMAGE	TOTAL ECONOMIC LOSS	ACCIDENT RATE
				PROPERTY DAMAGE	INJURY	FATAL	TOTAL ACCIDENT	INJURED	KILLED			
US 10	MONTANA-IDAHO LINE	46.6	1334	53	19		72	26	51160	77160	3.2	
US 10	SUPERIOR CITY LIMITS	2.2	CITY									
US 10	SUPERIOR CITY LIMITS	27.4	1462	30	10		40	12	37590	49590	2.7	
US 10	ALBERTON CITY LIMITS	1.3	CITY									
US 10	ALBERTON CITY LIMITS	.8	1533	3	1		4	1	1690	2690	8.9	
US 10	MISSOULA COUNTY LINE	12.8	1627	7	6		13	7	7010	14010	1.7	
US 10	FAS 263	6.9	1692	9	3	1	13	10	13280	45280	3.1	
US 10	FAP 5-US93	7.0	4215	11	6	1	18	10	8770	40770	1.7	
US 10	MISSOULA CITY LIMITS	2.5	CITY									
US 10	MISSOULA CITY LIMITS	6.0	4987	17	12	1	30	21	13550	56550	2.7	
US 10	FAP 24-MONT. 20	12.1	2453	34	7		41	11	17470	28470	3.8	
US 10	TOWN OF CLINTON	8.5	2026	13	2		15	2	10430	12430	2.4	
US 10	GRANITE COUNTY LINE	23.1	2063	27	10		37	17	25810	42810	2.1	
US 10	DRUMMOND CITY LIMITS	.9	CITY									
US 10	DRUMMOND CITY LIMITS	1.4	2290	2			2		1560	1560	1.7	
US 10	FAS 271	4.7	2105	7	4		11	6	6030	12030	3.0	
US 10S	POWELL COUNTY LINE	14.0	2148	12	3		15	6	16590	22590	1.4	
US 10S	FAP 8-US10N	4.8	1626				NONE					
US 10S	FAS 407	5.7	1722	9	1		10	1	3770	4770	2.8	
US 10S	DEER LODGE CITY LIMITS	1.1	CITY									
US 10S	DEER LODGE CITY LIMITS											

ROUTE NO.	SECTION DESCRIPTION	SECTION LENGTH	AVERAGE DAILY TRAFFIC	NO. OF ACCIDENTS				NO. OF PEOPLE		AMOUNT OF PROPERTY DAMAGE	TOTAL ECONOMIC LOSS	ACCIDENT RATE
				PROPERTY DAMAGE	INJURY	FATAL	TOTAL ACCIDENT	INJURED	KILLED			
US 10S	DEER LODGE CITY LIMITS	8.6	2126	12	5		17	8	13470	21470	2.5	
US 10S	DEER LODGE CO. LINE	2.1	1601	1			1		850	850	.8	
US 10S	FAS 273	4.8	2055	3	4		7	5	6200	11200	1.9	
US 10S	FAP 47-MONT. 48	4.4	1430	3		1	4	1	1170	24170	1.7	
US 10S	FAS 275	3.3	1409	2	1		3	2	1400	3400	1.8	
US 10S	FAP 19-US10A	.6	2913	8	2		10	2	3510	5510	15.7	
US 10S	SILVER BOW CO. LINE	8.6	2967	21	8	2	31	14	20360	100360	3.3	
US 10S	FAP 3-US91	3.5	4861	27	14		41	21	20130	41130	6.6	
US 10S	BREWERY BY PASS	1.1	4600		1		1	1	800	1800	.5	
US 10S	BUTTE CITY LIMITS	3.0	CITY									
US 10S	BUTTE CITY LIMITS	1.5	5247	3	7		10	27	7140	34140	3.5	
US 10S	FAS 392	.8	4593	2	1		3	1	1300	2300	2.2	
US 10S	FAS 393	8.9	2437	16	9	1	26	13	17930	52930	3.3	
US 10S	JEFFERSON CO. LINE	8.7	1628	15	4	2	21	8	13610	87610	4.1	
US 10S	FAP 29-MONT. 41	8.3	1478	7	1		8	1	4980	5980	1.8	
US 10S	FAS 401	.1	2145	1			1		120	120	12.8	
US 10S	WHITEHALL CITY LIMITS	1.0	CITY									
US 10S	WHITEHALL CITY LIMITS	5.4	1476		1		1	2	1750	3750	.3	
US 10S	FAS 281	13.7	1244	13	2	2	17	4	9430	57430	2.7	
US 10S	FAP 13-MONT. 1	5.3	1163	3			3		450	450	1.3	
US 10S	BROADWATER CO. LINE											

ROUTE NO.	SECTION DESCRIPTION	SECTION LENGTH	AVERAGE DAILY TRAFFIC	NO. OF ACCIDENTS				NO. OF PEOPLE		AMOUNT OF PROPERTY DAMAGE	TOTAL ECONOMIC LOSS	ACCIDENT RATE
				PROPERTY DAMAGE	INJURY	FATAL	TOTAL ACCIDENT	INJURED	KILLED			
US 10S	BROADWATER CO. LINE	4.6	1190	2			2			400	400	1.0
US 10	FAP 8-US10N	.1	1741	1	1		2	1		2000	3000	31.5
US 10	GALLATIN CO. LINE	2.2	1756	2			2			830	830	1.4
US 10	THREE FORKS CITY LIMITS	.9	CITY									
US 10	THREE FORKS CITY LIMITS	2.5	1909	3	1		4	1		1250	2250	2.3
US 10	FAS 286	8.4	1892	16	6	1	23	9	1	11700	42700	4.0
US 10	MANHATTAN CITY LIMITS	.8	CITY									
US 10	MANHATTAN CITY LIMITS	8.5	1963	2	2	1	5	2	1	2100	26100	.8
US 10	BELGRADE CITY LIMITS	.9	CITY									
US 10	BELGRADE CITY LIMITS	6.1	3060	13	6		19	6		7180	15180	2.8
US 10	FAS 411	2.4	3864	12	2		14	2		6630	8630	4.1
US 10	BOZEMAN CITY LIMITS	2.7	CITY									
US 10	BOZEMAN CITY LIMITS	12.1	2259	28	11	1	40	21	1	28240	71240	4.0
US 10	PARK COUNTY LINE	10.8	2075	13	3		16	4		11160	15160	2.0
US 10	LIVINGSTON CITY LIMITS	2.0	CITY									
US 10	LIVINGSTON CITY LIMITS	5.1	2652	6	2	1	9	2	5	4930	116930	1.8
US 10	FAP 11-US89	13.6	1712	23	9		32	12		19070	31070	3.8
US 10	SWEETGRASS CO. LINE	14.4	1440	12	7	1	20	14	1	13810	49810	2.6
US 10	BIG TIMBER CITY LIMITS	.9	CITY									
US 10	BIG TIMBER CITY LIMITS	22.0	1183	16	8		24	14		19480	33480	2.5
US 10	STILLWATER COUNTY LINE											

ROUTE NO.	SECTION DESCRIPTION	SECTION LENGTH	AVERAGE DAILY TRAFFIC	NO. OF ACCIDENTS				NO. OF PEOPLE		AMOUNT OF PROPERTY DAMAGE	TOTAL ECONOMIC LOSS	ACCIDENT RATE
				PROPERTY DAMAGE	INJURY	FATAL	TOTAL ACCIDENT	INJURED	KILLED			
US 10	STILLWATER COUNTY LINE	16.9	1363	11	6		17	7		9780	16780	2.0
US 10	FAS 306	.7	1747	1			1			250	250	2.2
US 10	COLUMBUS CITY LIMITS	.6	CITY									
US 10	COLUMBUS CITY LIMITS	20.3	1653	17	6	1	24	9	1	22650	53650	2.0
US 10	YELLOWSTONE CO. LINE	5.1	2347	10	2		12	4		6380	10380	2.7
US 10	LAUREL CITY LIMITS	1.0	CITY									
US 10	LAUREL CITY LIMITS	11.5	5522	62	12	1	75	22	1	35230	79230	3.2
US 10	FAS 305	1.6	7731	32	6		38	12		12650	24650	8.4
US 10	SOUTHSIDE BY-PASS	.2	11760	1			1			300	300	1.2
US 10	BILLINGS CITY LIMITS	2.6	CITY									
US 10	BILLINGS CITY LIMITS	.3	10035	8	2		10	2		2700	4700	9.1
US 10	FAP 16-US87	3.5	6028	21	2		23	2		6550	8550	3.0
US 10	FAP 16-US87	7.6	2452	8	2	1	9	4	1	4810	30810	1.3
US 10	FAS 304	4.9	2112	2	4		6	7		10300	17300	1.6
US 10	FAS 303	4.6	1842	5	1		6	1		3730	4730	1.9
US 10	FAS 303	8.5	1917	3	3	1	7	3	1	1720	26720	1.2
US 10	FAS 303	25.2	1196	13	1		14	1		3800	4800	1.3
US 10	FAP 48-MONT. 47	3.4	1081	1	1		2	2		470	2470	1.5
US 10	TREASURE CO. LINE	13.3	1132	5	3	1	9	7	2	5720	56720	1.6
US 10	FAS 311	5.0	1304				NONE					
US 10	FAS 312											

ROUTE NO.	SECTION DESCRIPTION	SECTION LENGTH	AVERAGE DAILY TRAFFIC	NO. OF ACCIDENTS				NO. OF PEOPLE		AMOUNT OF PROPERTY DAMAGE	TOTAL ECONOMIC LOSS	ACCIDENT RATE
				PROPERTY DAMAGE	INJURY	FATAL	TOTAL ACCIDENT	INJURED	KILLED			
US 10	FAS 312	10.5	1136	6	1		7	1	2600	3600	1.6	
US 10	ROSEBUD CO. LINE											
US 10	FAS 315	9.5	1070	1	3		4	6	1570	7570	1.1	
US 10	FORSYTH CITY LIMITS	6.1	1328	7	3		10	7	5120	12120	3.4	
US 10	FORSYTH CITY LIMITS	1.8	CITY									
US 10	CUSTER CO. LINE	25.3	1375	21	7	1	29	11	15870	48870	2.3	
US 10	MILES CITY CITY LIMITS	18.6	1316	16	8	2	26	16	32770	114770	2.9	
US 10	MILES CITY CITY LIMITS	1.3	CITY									
US 10	FAP 17-US10	1.3	2575	4	2		6	2	3560	5560	4.9	
US 12	FAS 333	13.7	515	7	1		8	2	3250	5250	3.1	
US 12	FALLON COUNTY LINE	33.8	455	11	5		16	7	4990	11990	2.9	
US 12	FAS 320	6.1	459	4			4		2150	2150	3.9	
US 12	PLEVNA CITY LIMITS	12.4	489	4	1		5	2	1290	3290	2.3	
US 12	PLEVNA CITY LIMITS	.8	CITY									
US 12	BAKER CITY LIMITS	11.7	713	1		2	3	3	2240	49240	1.0	
US 12	BAKER CITY LIMITS	1.4	CITY									
US 12	MONT.-NORTH DAKOTA LINE	11.7	582	1	1		2	1	1480	2480	.8	
	FAP LOOP #2 BREW.B.P.											
	FAP 2-US10S											
	BUTTE CITY LIMITS	1.4	3365	2			2		780	780	1.2	

ROUTE NO.	SECTION DESCRIPTION	SECTION LENGTH	AVERAGE DAILY TRAFFIC	NO. OF ACCIDENTS				NO. OF PEOPLE		AMOUNT OF PROPERTY DAMAGE	TOTAL ECONOMIC LOSS	ACCIDENT RATE
				PROPERTY DAMAGE	INJURY	FATAL	TOTAL ACCIDENT	INJURED	KILLED			
US 91	MONT. IDAHO LINE	15.2	516	7	3		10	4	7910	11910	3.5	
US 91	LIMA CITY LIMITS	1.1	CITY									
US 91	LIMA CITY LIMITS	26.6	551	7	3	1	11	4	5830	53830	2.1	
US 91	FAS 324	21.3	750	20	5	1	26	7	26480	55480	4.5	
US 91	DILLON CITY LIMITS	1.4	CITY									
US 91	DILLON CITY LIMITS	.1	2490	1			1		690	690	11.0	
US 91	FAP 49-MONT. 41	22.5	833	10	1		11	1	5710	6710	1.6	
US 91	MADISON CO. LINE	7.3	661	1	1		2	4	1130	5130	1.1	
US 91	SILVER BOW CO. LINE	10.0	702	2	5		7	8	4990	12990	2.7	
US 91	FAP 46-MONT. 43	19.5	835	8	4		12	5	7540	12540	2.0	
US 91	FAP 2-US10	3.5	4861	27	14		41	21	20130	41130	6.6	
US 91	BREWERY BY PASS	1.1	4600		1		1	1	800	1800	.5	
US 91	BUTTE CITY LIMITS	1.6	CITY									
US 91	BUTTE CITY LIMITS	3.8	2307	13	3		16	4	8430	12430	5.0	
US 91	JEFFERSON CO. LINE	30.3	981	30	6	2	38	12	19150	75150	3.5	
US 91	BOULDER CITY LIMITS	1.1	CITY									
US 91	BOULDER CITY LIMITS	25.7	870	27	11	1	39	15	15330	52330	4.8	
US 91	LEWIS & CLARK CO. LINE	2.1	1196	1	2		3	2	400	2400	3.3	
US 91	HELENA CITY LIMITS	3.7	CITY									
US 91	HELENA CITY LIMITS	6.1	1841	13	2	1	16	6	11020	39020	3.9	
US 91	FAS 279											

ROUTE NO.	SECTION DESCRIPTION	SECTION LENGTH	AVERAGE DAILY TRAFFIC	NO. OF ACCIDENTS				NO. OF PEOPLE		AMOUNT OF PROPERTY DAMAGE	TOTAL ECONOMIC LOSS	ACCIDENT RATE
				PROPERTY DAMAGE	INJURY	FATAL	TOTAL ACCIDENT	INJURED	KILLED			
US 91	FAS 279	27.2	1084	33	15	1	49	23	1	27040	72040	4.6
US 91	FAP 9-MONT. 33	15.1	948	14	2	1	17	2	1	15670	39670	3.3
US 91	CASCADE CO. LINE	16.3	980	19	9		28	15		16200	31200	4.8
US 91	CASCADE CITY LIMITS	1.1	CITY									
US 91	CASCADE CITY LIMITS	14.2	1249	14	10	2	26	25	2	15870	84870	4.0
US 91	FAS 330	9.3	1429	11	5		16	13		8180	21180	3.3
US 91	GT. FALLS CITY LIMITS	2.7	CITY									
US 91	GT. FALLS CITY LIMITS	9.4	3552	19	10		29	16		17340	33340	2.4
US 89	FAP 21-US91	7.6	1649	6	3	1	10	7	1	3810	32810	2.2
US 89	FAP 24-MONT. 20	12.1	663	11	5		16	7		6200	13200	5.5
US 89	TETON CO. LINE	3.0	907	8	7		15	11		9120	20120	15.1
US 89	FAIRFIELD CITY LIMITS	.9	CITY									
US 89	FAIRFIELD CITY LIMITS	16.5	549	7	2		9	2		2700	4700	2.7
US 89	CHOTEAU CITY LIMITS	1.2	CITY									
US 89	CHOTEAU CITY LIMITS	20.8	480	5	3		8	4		2940	6940	2.2
US 89	FAS 219	5.6	227				NONE					
US 89	PONDERA CO. LINE	16.0	248	3	6	1	10	11	1	6750	39750	6.9
US 89	FAS 216	5.0	340	2			2			500	500	3.2
US 89	GLACIER CO. LINE	21.6	399	5	1		6	1		3500	4500	1.9
US 89	FAP 1-US2	2.3	1740	8			8			3500	3500	5.5
US 89	FAP 1-US2											

ROUTE NO.	SECTION DESCRIPTION	SECTION LENGTH	AVERAGE DAILY TRAFFIC	NO. OF ACCIDENTS				NO. OF PEOPLE		AMOUNT OF PROPERTY OAMAGE	TOTAL ECONOMIC LOSS	ACCIDENT RATE
				PROPERTY OAMAGE	INJURY	FATAL	TOTAL ACCIDENT	INJURED	KILLED			
US 10A	FAP 2-US10	15.2	1472	18	7		25	11	11600	22600	3.1	
US 10A	LAKE COUNTY LINE	12.4	1618	14	7		21	10	9150	19150	2.9	
US 93	FAP 6-US10A	5.1	1464	6	2	2	10	3	5120	52120	3.7	
US 93	ST.IGNATIUS CITY LIMITS	.1	CITY									
US 93	ST.IGNATIUS CITY LIMITS	9.3	1424	7	3		10	4	9470	13470	2.1	
US 93	FAS 212	4.5	1517	2	4		6	4	1670	5670	2.4	
US 93	RONAN CITY LIMITS	.9	CITY									
US 93	RONAN CITY LIMITS	11.6	1355	23	4	1	28	10	9130	41130	4.9	
US 93	FAP 52-MONT. 35	1.3	1754	1			1		140	140	1.2	
US 93	POLSON CITY LIMITS	.7	CITY									
US 93	POLSON CITY LIMITS	16.6	587	3	3		6	3	1600	4600	1.7	
US 93	FAP 36-MONT. 28	5.6	616	1	1		2	1	180	1180	1.6	
US 93	FAS 352	10.3	587	6	1		7	1	3490	4490	3.2	
US 93	FLATHEAD CO. LINE	11.0	1035	14	4		18	5	8480	13480	4.3	
US 93	FAS 208	5.5	2496	9	2		11	4	4280	8280	2.2	
US 93	FAS 207 & FAS 317	1.8	3116	2	1		3	1	440	1440	1.5	
US 93	KALISPELL CITY LIMITS	1.9	CITY									
US 93	KALISPELL CITY LIMITS	11.9	1178	5	4		9	6	2260	8260	1.8	
US 93	FAP 38-MONT. 40	1.4	2491	3	1		4	1	680	1680	3.1	
US 93	WHITEFISH CITY LIMITS	1.0	CITY									
US 93	WHITEFISH CITY LIMITS											

FAP NO 7

ROUTE NO.	SECTION DESCRIPTION	SECTION LENGTH	AVERAGE DAILY TRAFFIC	NO. OF ACCIDENTS				NO. OF PEOPLE		AMOUNT OF PROPERTY DAMAGE	TOTAL ECONOMIC LOSS	ACCIDENT RATE
				PROPERTY DAMAGE	INJURY	FATAL	TOTAL ACCIDENT	INJURED	KILLED			
US 93	MONTANA-IDAHO LINE	30.5	435	9	5		14	7		4850	11850	2.9
US 93	DARBY CITY LIMITS	.7	CITY									
US 93	DARBY CITY LIMITS	13.3	1085	7	3		10	5		7720	12720	1.9
US 93	FAP 35-MONT. 38	2.1	1987	2			2			470	470	1.3
US 93	HAMILTON CITY LIMITS	1.4	CITY									
US 93	HAMILTON CITY LIMITS	11.0	1269	8	6		14	6		6700	12700	2.7
US 93	FAS 370	7.7	974	1	2		3	3		92100	95100	1.1
US 93	FAS 269	10.0	1190	5	1	1	7	2	1	2820	26820	1.6
US 93	MISSOULA CO. LINE	6.8	1409	18	3		21	5		8220	13220	6.0
US 93	FAS 412	9.2	2840	22	1		23	2		6630	8630	2.4
US 93	FAS 390-FAP 7 SPUR	.4	5850	2			2			150	150	2.3
US 93	MISSOULA CITY LIMITS	1.4	CITY									
	FAP 2-US10											
	ORANGE ST. SPUR											
	FAP 7 SOUTH OF MISSOULA	.2	4250				NONE					
	MISSOULA CITY LIMITS											

FAP NO 8

ROUTE NO.	SECTION DESCRIPTION	SECTION LENGTH	AVERAGE DAILY TRAFFIC	NO. OF ACCIDENTS				NO. OF PEOPLE		AMOUNT OF PROPERTY DAMAGE	TOTAL ECONOMIC LOSS	ACCIDENT RATE
				PROPERTY DAMAGE	INJURY	FATAL	TOTAL ACCIDENT	INJURED	KILLED			
US 10N	FAP 2-US10	3.6	1121	1			1			300	300	.7
US 10N	FAS 407	9.3	1157	7	2		9	2		6220	8220	2.3
US 10N	FAS 272	14.9	1033	15	6		21	8		9430	17430	3.7
US 10N	LEWIS & CLARK CO. LINE	13.0	1182	13	8		21	10		18600	28600	3.7
US 10N	FAS 356	1.3	3243	1	1		2	2		650	2650	1.3
US 10N	HELENA CITY LIMITS	3.5	CITY									
US 10N	HELENA CITY LIMITS	3.1	3335	8	5		13	9		4900	13900	3.4
US 10N	EAST HELENA CITY LIMITS	1.3	CITY									
US 10N	EAST HELENA CITY LIMITS	4.7	1451	1	1		2	1		220	1220	.8
US 10N	JEFFERSON CO. LINE	1.5	1354				NONE					
US 10N	BROADWATER CO. LINE	21.0	1149	7	2	1	10	6	1	9000	37000	1.1
US 10N	TOWNSEND CITY LIMITS	1.1	CITY									
US 10N	TOWNSEND CITY LIMITS	10.4	973	1	1		2	2		750	2750	.5
US 10N	FAS 285 NEAR TOSTON	21.0	859	4		2	6	3	3	1700	70700	.9
US 10N	FAP 2-US10											

FAP NO 11

ROUTE NO.	SECTION DESCRIPTION	SECTION LENGTH	AVERAGE DAILY TRAFFIC	NO. OF ACCIDENTS				NO. OF PEOPLE		AMOUNT OF PROPERTY DAMAGE	TOTAL ECONOMIC LOSS	ACCIDENT RATE
				PROPERTY DAMAGE	INJURY	FATAL	TOTAL ACCIDENT	INJURED	KILLED			
US 89	YELLOWSTONE PARK	.5	943				NONE					
US 89	GARDINER	30.9	517	12	1		13	1	3640	4640	2.2	
US 89	FAS 362	24.2	876	31	9	1	41	13	32530	67530	5.3	
US 89	LIVINGSTON CITY LIMITS	1.3	CITY									
US 89	LIVINGSTON CITY LIMITS	5.1	2652	6	2	1	9	2	4930	116930	1.8	
US 89	FAP 2-US10	14.3	664				NONE					
US 89	CLYDE PARK CITY LIMITS	.5	CITY									
US 89	CLYDE PARK CITY LIMITS	8.2	491	2			2		1670	1670	1.4	
US 89	FAS 339	14.2	171	1	1		2	1	650	1650	2.3	
US 89	MEAGHER CO. LINE	11.6	145	1	1		2	1	1050	2050	3.3	
US 89	FAS 294	8.0	224	2	2		4	3	1650	4650	6.1	
US 89	FAP 14-MONT. 6	8.2	763	4			4		730	730	1.8	
US 89	WHITE SUL.SPGS.CITY LIMIT	1.2	CITY									
US 89	WHITE SUL.SPGS.CITY LIMIT	2.1	664				NONE					
US 89	FAP 14-MONT. 6	28.5	163	7			7		2940	2940	4.1	
US 89	CASCADE CO. LINE	7.4	186	3	1		4	1	1500	2500	8.0	
US 89	NEIHART CITY LIMITS	3.1	CITY									
US 89	NEIHART CITY LIMITS	32.8	233	9	2	1	12	4	3330	29330	4.3	
US 89	FAP 15-US87	4.1	931	7	4		11	10	5290	15290	7.9	
US 89	FAS 331	12.5	1377	14	2	1	17	5	8320	35320	2.7	
	FAS 227 & 228											

FAP NO 14

ROUTE NO.	SECTION DESCRIPTION	SECTION LENGTH	AVERAGE DAILY TRAFFIC	NO. OF ACCIDENTS				NO. OF PEOPLE		AMOUNT OF PROPERTY DAMAGE	TOTAL ECONOMIC LOSS	ACCIDENT RATE
				PROPERTY DAMAGE	INJURY	FATAL	TOTAL ACCIDENT	INJURED	KILLED			
MO 6	FAP 8-US10N	.9	CITY									
MO 6	TOWNSEND CITY LIMITS	22.6	514	4	1		5	1	780	1780	1.2	
MO 6	MEAGHER CO. LINE	10.0	416	1	1		2	1	950	1950	1.3	
MO 6	FAP 11-US89	8.2	763	4			4		730	730	1.8	
MO 6	WHITE SUL.SPGS.CITY LIMIT	1.2	CITY									
MO 6	WHITE SUL.SPGS.CITY LIMIT	2.1	664				NONE					
MO 6	FAP 11-US89	31.2	396	3	2	1	6	8	6130	36130	1.3	
MO 6	FAS 294	1.2	429	2			2		800	800	10.6	
MO 6	WHEATLAND CO. LINE	10.8	452	1	1		2	1	1600	2600	1.1	
MO 6	FAS 296	11.3	796	9	1	1	11	1	4320	27320	3.4	
MO 6	HARLOWTON CITY LIMITS	1.0	CITY									
MO 6	HARLOWTON CITY LIMITS	.5	1142	3		1	4	3	3390	50390	19.2	
MO 6	FAP 45-MONT. 19	15.3	701	11	2	1	14	2	6930	30930	3.6	
MO 6	FAS 297	.1	701				NONE					
MO 6	FAS 394	6.3	625	2	4		6	6	7150	13150	4.2	
MO 6	GOLDEN VALLEY CO. LINE	6.9	628	2			2		850	850	1.3	
MO 6	RYEGATE CITY LIMITS	1.0	CITY									
MO 6	RYEGATE CITY LIMITS	15.6	718	7	4	1	12	8	5820	35820	2.9	
MO 6	FAP 53-MONT. 3	5.6	303	6			6		2650	2650	9.7	
MO 6	MUSSELSHELL CO. LINE	11.0	304	2	2		4	3	2090	5090	3.3	
MO 6	FAS 381											

ROUTE NO.	SECTION DESCRIPTION	SECTION LENGTH	AVERAGE DAILY TRAFFIC	NO. OF ACCIDENTS				NO. OF PEOPLE		AMOUNT OF PROPERTY DAMAGE	TOTAL ECONOMIC LOSS	ACCIDENT RATE
				PROPERTY DAMAGE	INJURY	FATAL	TOTAL ACCIDENT	INJURED	KILLED			
US 87	FAP 11-US89	7.2	852	4	3		7	3	2530	5530	3.1	
US 87	JUDITH BASIN CO. LINE	29.6	737	21	4		25	4	12280	16280	3.1	
US 87	FAS 230	22.0	844	6	4		10	7	5150	12150	1.5	
US 87	HOBSON CITY LIMITS	.2	CITY									
US 87	HOBSON CITY LIMITS	5.5	991	5	2		7	3	4180	7180	3.5	
US 87	FERGUS CO. LINE	.5	1019	3	1		4	2	2020	4020	21.5	
US 87	FAP 45-MONT. 19	14.3	1180	8	4	2	14	8	6860	58860	2.3	
US 87	LEWISTOWN SPUR	1.9	1000	1	2		3	3	2740	5740	4.3	
US 87	LEWISTOWN CITY LIMITS	2.0	CITY									
US 87	LEWISTOWN CITY LIMITS	29.5	662	14	8		22	10	10340	20340	3.1	
MO 18	FAP 16-US87	10.4	275	1			1		400	400	1.0	
MO 18	PETROLEUM CO. LINE	12.3	263	4	1		5	1	1240	2240	4.2	
MO 18	WINNETT CITY LIMITS	.9	CITY									
MO 18	WINNETT CITY LIMITS	21.7	317	1			1		600	600	.4	
MO 18	GARFIELD CO. LINE	30.2	278	1	2		3	3	2730	5730	1.0	
MO 18	TOWN OF EDWARDS	23.5	299	3	1		4	2	1300	3300	1.6	
MO 18	FAP 18-MONT. 22	.2	538				NONE					
MO 18	JORDAN CITY LIMITS	.6	CITY									
MO 18	JORDAN CITY LIMITS	35.6	200	6			6		4070	4070	2.3	
MO 18	MCCONE CO. LINE	19.0	206	3			3		980	980	2.1	
MO 18	FAS 253											

FAP NO 15

ROUTE NO.	SECTION DESCRIPTION	SECTION LENGTH	AVERAGE DAILY TRAFFIC	NO. OF ACCIDENTS				NO. OF PEOPLE		AMOUNT OF PROPERTY DAMAGE	TOTAL ECONOMIC LOSS	ACCIDENT RATE
				PROPERTY OAMAGE	INJURY	FATAL	TOTAL ACCIDENT	INJURED	KILLED			
MO 18	FAS 253	11.0	371	1	1	2	4	2	2	1870	47870	2.7
MO 18	CIRCLE CITY LIMITS	1.4	CITY									
MO 18	CIRCLE CITY LIMITS	10.2	441	2	1		3	2		1980	3980	1.8
MO 18	DAWSON CO. LINE	15.0	406	4	3		7	4		3750	7750	3.1
MO 18	TOWN OF LINDSAY	21.5	565	4	1		5	2		2270	4270	1.1
US 10	FAP 17-US10	.7	4753	9	1		10	1		2960	3960	8.2
US 10	FAP 20-MONT. 16	.8	7623	7			7			1070	1070	3.1
MO 10	GLENDIVE CITY LIMITS	1.4	CITY									
US 10	GLENDIVE CITY LIMITS	20.2	1073	12	5	1	18	8	1	10800	40800	2.3
US 10	WIBAUX CO. LINE	6.5	960	1			1			70	70	.4
MO 10	WIBAUX CITY LIMITS	1.1	CITY									
US 10	WIBAUX CITY LIMITS	7.7	980	2	3		5	3		1950	4950	1.8
	MONTANA-N.D. LINE											
	LEWISTOWN SPUR											
US	FAP 15-US87	2.5	546				NONE					
	LEWISTOWN CITY LIMITS											

ROUTE NO.	SECTION DESCRIPTION	SECTION LENGTH	AVERAGE DAILY TRAFFIC	NO. OF ACCIDENTS				NO. OF PEOPLE		AMOUNT OF PROPERTY DAMAGE	TOTAL ECONOMIC LOSS	ACCIDENT RATE
				PROPERTY DAMAGE	INJURY	FATAL	TOTAL ACCIDENT	INJURED	KILLED			
US 87	MONT.-WYOMING STATE LINE	22.6	814	2	4		6	4	16330	20330	.9	
US 87	FAS 463 NEAR LODGEGRASS	19.2	1018	9	11		20	14	65700	79700	2.8	
US 87	FAP 37-MONT. 8	12.7	1633	12	3		15	5	34880	39880	2.0	
US 87	FAS 384	1.7	2302	4	2		6	4	2570	6570	4.2	
US 87	HARDIN CITY LIMITS	1.0	CITY									
US 87	HARDIN CITY LIMITS	22.2	1131	15	4	1	20	8	9520	39520	2.2	
US 87	YELLOWSTONE CO. LINE	25.9	1628	35	12		47	14	33360	47360	3.1	
US 87	FAP 2-US10	3.5	6028	20	2		22	2	6090	8090	2.9	
US 87	FAP 2-US10	20.4	683	5	3		8	4	4750	8750	1.6	
US 87	MUSSELSHELL CO. LINE	22.5	652	9	2		11	2	4880	6880	2.1	
US 87	TOWN OF KLEIN	3.0	1490	2	1		3	1	1960	2960	1.8	
US 87	FAP 14-MONT. 6	.3	1911	6	1	1	8	1	3530	26530	38.2	
US 87	FAS 309	.7	2500	1	1		2	1	60	1060	3.1	
US 87	ROUNDUP CITY LIMITS	1.6	CITY									
US 87	ROUNDUP CITY LIMITS	19.6	546	3	4		7	6	3360	9360	1.8	
US 87	FAS 244	1.2	325	1	1		2	3	1220	4220	14.0	
US 87	PETROLEUM CO. LINE	4.9	331	1			1		300	300	1.7	
US 87	FERGUS CO. LINE	18.0	325	3	2		5	3	3550	6550	2.3	
US 87	GRASS RANGE CITY LIMITS	.5	CITY									
US 87	GRASS RANGE CITY LIMITS	1.0	530		1		1	1	450	1450	5.2	
US 87	FAP 15-MONT. 18											

FAP NO 17

ROUTE NO.	SECTION DESCRIPTION	SECTION LENGTH	AVERAGE DAILY TRAFFIC	NO. OF ACCIDENTS				NO. OF PEOPLE		AMOUNT OF PROPERTY DAMAGE	TOTAL ECONOMIC LOSS	ACCIDENT RATE
				PROPERTY DAMAGE	INJURY	FATAL	TOTAL ACCIDENT	INJURED	KILLED			
US 10	FAP 2-US10	22.3	1155	9	3	2	14	7	2	23190	74190	1.5
US 10	PRAIRIE COUNTY LINE	13.1	1048	9			9			2630	2630	1.8
US 10	TERRY CITY LIMITS	1.0	CITY									
US 10	TERRY CITY LIMITS	.1	1598				NONE					
US 10	FAS 253	14.6	1037	7	1	1	9	1	1	4400	27400	1.6
US 10	DAWSON CO. LINE	21.0	1103	6	1		7	1		4620	5620	.8
	FAP 15-MONT. 18											
	FAP NO 18											
MO 22	FAP 2-US10	1.0	CITY									
MO 22	MILES CITY CITY LIMITS	19.2	316	2			2			400	400	.9
MO 22	ROSEBUD CO. LINE	18.0	165	1	1		2	2		990	2990	1.8
MO 22	GARFIELD CO. LINE	45.0	155	3			3			4350	4350	1.2
	FAP 15-MONT. 18											

FAP NO 21

ROUTE NO.	SECTION DESCRIPTION	SECTION LENGTH	AVERAGE DAILY TRAFFIC	NO. OF ACCIDENTS				NO. OF PEOPLE		AMOUNT OF PROPERTY DAMAGE	TOTAL ECONOMIC LOSS	ACCIDENT RATE
				PROPERTY DAMAGE	INJURY	FATAL	TOTAL ACCIDENT	INJURED	KILLED			
US 91	FAP 3-US89	10.8	1340	5	2		7	4	3050	7050	1.3	
US 91	TETON CO. LINE	10.8	1078	4	1	1	6	3	2160	27160	1.4	
US 91	FAS 221 & 379	11.0	1260	2			2		1450	1450	.4	
US 91	PONDERA CO. LINE	4.5	1236		1		1	1	18000	19000	.5	
US 91	FAS 365	10.4	1424	3	2		5	4	2520	6520	.9	
US 91	FAS 219	.6	2217			1	1		900	22900	2.1	
US 91	CONRAD CITY LIMITS	.9	CITY									
US 91	CONRAD CITY LIMITS	6.0	1654	8	2		10	4	2710	6710	2.8	
US 91	FAS 366	3.0	1497	5	2		7	6	2090	8090	4.3	
US 91	FAS 216	6.6	1091	1	1		2	1	1170	2170	.8	
US 91	TOOLE CO. LINE	8.7	1166	5	2	1	8	2	95220	141220	2.2	
US 91	SHELBY CITY LIMITS	1.4	CITY									
US 91	SHELBY CITY LIMITS	15.8	1050	9			9		3200	3200	1.5	
US 91	FAS 215 & 410	9.9	959	6	1		7	1	1810	2810	2.0	
US 91	SUNBURST CITY LIMITS	1.2	CITY									
US 91	SUNBURST CITY LIMITS	7.7	682	2	1		3	1	1800	2800	1.6	
US 91	FAS 214	.1	577				NONE					
	MONTANA-CANADA LINE											

ROUTE NO.	SECTION DESCRIPTION	SECTION LENGTH	AVERAGE DAILY TRAFFIC	NO. OF ACCIDENTS				NO. OF PEOPLE		AMOUNT OF PROPERTY DAMAGE	TOTAL ECONOMIC LOSS	ACCIDENT RATE
				PROPERTY DAMAGE	INJURY	FATAL	TOTAL ACCIDENT	INJURED	KILLED			
MO 13	FAP 32-MONT. 13	.5	CITY									
MO 13	SCOBAY CITY LIMITS	11.1	512	2			2		750	750	1.0	
MO 5	FAP 31-MONT. 13	6.5	302				NONE					
MO 5	SHERIDAN CO. LINE	12.4	391	2	3		5	3	5750	8750	2.8	
MO 5	FAS 374	10.9	612	4	1	1	6	2	6310	52310	2.5	
MO 5	PLENTYWOOD CITY LIMITS	1.2	CITY									
MO 5	PLENTYWOOD CITY LIMITS	1.0	1107				NONE					
MO 16	FAP 30-MONT. 5	12.5	675	5	4		5	6	6530	12530	2.9	
MO 16	FAS 258	8.2	543	1	1		2	1	1550	2550	1.2	
MO 16	MEDICINE LAKE CITY LIMITS	.3	CITY									
MO 16	MEDICINE LAKE CITY LIMITS	7.5	500	1	1		2	1	1300	2300	1.5	
MO 16	ROOSEVELT CO. LINE	3.4	515	1	1		2	1	1300	2300	3.1	
MO 16	FROID CITY LIMITS	.6	CITY									
MO 16	FROID CITY LIMITS	13.3	708	4	1		5	1	2650	3650	1.5	
MO 16	CULBERTSON CITY LIMITS	.9	CITY									
MO 16	CULBERTSON CITY LIMITS	2.4	486	1			1		750	750	2.3	
MO 16	RICHLAND CO. LINE	21.0	400	6	1		7	1	3020	4020	2.3	
MO 16	FAS 201	12.4	627	3	1		4	4	1880	2280	1.4	
MO 16	SIDNEY CITY LIMITS	.7	CITY									
MO 16	FAP 20-MONT. 16											

ROUTE NO.	SECTION DESCRIPTION	SECTION LENGTH	AVERAGE DAILY TRAFFIC	NO. OF ACCIDENTS				NO. OF PEOPLE		AMOUNT OF PROPERTY DAMAGE	TOTAL ECONOMIC LOSS	ACCIDENT RATE
				PROPERTY DAMAGE	INJURY	FATAL	TOTAL ACCIDENT	INJURED	KILLED			
MO 5	FAP 22-MONT. 16	23.4	282	6	6		12	10		11600	21600	5.0
MO 5	WESTBY CITY LIMITS	.8	CITY									
	MONT.-N.DAK. LINE											
	FAP NO 31											
MO 13	FAP 22-MONT. 5	.3	CITY									
MO 13	FLAXVILLE CITY LIMITS	6.2	206	1	2		3	3		2690	5690	6.4
MO 13	TOWN OF WHITETAILED	7.3	96				NONE					
	MONTANA-CANADA LINE											
	FAP NO 32											
MO 13	FAP 25-MONT. 13W.	4.1	136				NONE					
MO 13	FAP 1-US2	31.1	263	4	3	1	8	4	1	7550	33550	2.7
MO 13	DANIELS CO. LINE	15.6	289	1	1		2	2		3200	5200	1.2
MO 13	SCOBAY CITY LIMITS	.5	CITY									
	FAP 22 & FAS 248											

FAP NO 46

ROUTE NO.	SECTION DESCRIPTION	SECTION LENGTH	AVERAGE DAILY TRAFFIC	NO. OF ACCIDENTS				NO. OF PEOPLE		AMOUNT OF PROPERTY DAMAGE	TOTAL ECONOMIC LOSS	ACCIDENT RATE
				PROPERTY DAMAGE	INJURY	FATAL	TOTAL ACCIDENT	INJURED	KILLED			
MO 43	FAP 7-US93	.1	NON	EX.								
MO 43	MONTANA-IDAHO LINE				24.6	53				NONE		
MO 43	FAS 278	15.5	124	2	1		3	2	1280	3280	4.3	
MO 43	DEERLODGE CO. LINE	12.5	114		1		1	2	200	2200	1.9	
MO 43	FAS 274	2.5	157				NONE					
MO 43	SILVER BOW CO. LINE	1.7	170				NONE					
MO 43	BEAVERHEAD CO. LINE	15.2	201	2			2		640	640	1.8	
MO 43	SILVER BOW CO. LINE	3.3	312	1			1		280	280	2.7	
	FAP 3-US91											
	FAP NO 47											
MO 48	FAP 19-US10A	6.2	1004	5	3		8	4	8730	12730	3.5	
	FAP 2-US10											

FAP NO 50

ROUTE NO.	SECTION DESCRIPTION	SECTION LENGTH	AVERAGE DAILY TRAFFIC	NO. OF ACCIDENTS				NO. OF PEOPLE		AMOUNT OF PROPERTY DAMAGE	TOTAL ECONOMIC LOSS	ACCIDENT RATE
				PROPERTY DAMAGE	INJURY	FATAL	TOTAL ACCIDENT	INJURED	KILLED			
US 191	FAP 13-MONT. 1	2.5	383	1			1		280	280	2.9	
US 191	YELLOWSTONE PARK BOUNDARY	20.3	337	2	1		3	1	4150	5150	1.2	
US 191	YELLOWSTONE PARK BOUNDARY	24.6	392	1	3		4	4	12750	16750	1.1	
US 191	TOWN OF KARST KAMP	20.1	469	15	3		18	7	10480	17480	5.2	
US 191	FAS 345	6.1	942	9			9		3830	3830	4.3	
US 191	FAS 289-291	3.9	1412	6	2		8	3	3040	6040	4.0	
US 191	FAS 345	2.8	1673	6	1		7	7	3480	10480	4.1	
US 191	BOZEMAN CITY LIMITS	.3	CITY									
US 191	FAP 2-US10 IN BOZEMAN											
	FAP NO 51											
MO 23	FAP 15-MONT. 18	7.5	NON	EX.								
MO 23	DAWSON CO. LINE	18.7	NON	EX.								
MO 23	RICHEY CITY LIMITS	.5	NON	EX.								
MO 23	RICHEY CITY LIMITS	.3	NON	EX.								
MO 23	FAS 254 & 468	4.7	58				NONE					
MO 23	RICHLAND CO. LINE	16.8	67	2			2		2280	2280	4.9	
MO 23	CO. RD. TO LAMBERT	21.7	271	1			1		70	70	.5	
	FAP 20-MONT. 16											

FAP NO 52

ROUTE NO.	SECTION DESCRIPTION	SECTION LENGTH	AVERAGE DAILY TRAFFIC	NO. OF ACCIDENTS				NO. OF PEOPLE		AMOUNT OF PROPERTY DAMAGE	TOTAL ECONOMIC LOSS	ACCIDENT RATE
				PROPERTY DAMAGE	INJURY	FATAL	TOTAL ACCIDENT	INJURED	KILLED			
MO 35	FAP 5-US93	28.2	654	12	6		18	8	9490	17490	2.7	
MO 35	FLATHEAD CO. LINE	3.2	755	1	1		2	1	2250	3250	2.3	
MO 35	FAS 209	2.4	1136	2			2		240	240	2.0	
MO 35	FAS 208	11.6	611	6			6		1570	1570	2.3	
	FAP 1-US2											
	FAP NO 53											
MO 3	FAP 2 IN BILLINGS	1.0	CITY									
MO 3	BILLINGS CITY LIMITS	.1	5550				NONE					
MO 3	FAS 302	.8	3120				NONE					
MO 3	FAS 318	15.6	707	6			6		3960	3960	1.5	
MO 3	FAS 328	13.0	521	1		1	2	1	1350	24350	.8	
MO 3	BROADVIEW CITY LIMITS	.5	CITY									
MO 3	BROADVIEW CITY LIMITS	2.2	552		1		1	1	660	1660	2.3	
MO 3	GOLDEN VALLEY CO. LINE	11.1	567	2	2		4	4	4770	8770	1.7	
MO 3	LAVINA CITY LIMITS	.9	CITY									
MO 3	LAVINA CITY LIMITS	.4	666				NONE					
	FAP 14											



INDEX OF COUNTY REGISTRATION NUMBERS

COUNTY	REGIST. NUMBER	COUNTY	REGIST. NUMBER	COUNTY	REGIST. NUMBER
Beaverhead	18	Granite	46	Powell	28
Big Horn	22	Hill	12	Prairie	45
Blaine	24	Jefferson	51	Ravalli	13
Broadwater	43	Judith Basin	36	Richland	27
Carbon	10	Lake	15	Roosevelt	17
Carter	42	Lewis & Clark	5	Rosebud	29
Cascade	2	Liberty	48	Sanders	35
Chouteau	19	Lincoln	56	Sheridan	34
Custer	14	McCone	41	Silver Bow	1
Daniels	37	Madison	25	Stillwater	32
Dawson	16	Meagher	47	Sweet Grass	40
Deer Lodge	30	Mineral	54	Teton	31
Fallon	39	Missoula	4	Toole	21
Fergus	8	Musselshell	23	Treasure	33
Flathead	7	Park	49	Valley	20
Gallatin	6	Petroleum	55	Wheatland	44
Garfield	50	Phillips	11	Wibaux	52
Glacier	38	Pondera	26	Yellowstone	3
Golden Valley	53	Powder River	9		

LISTING OF PATROL SECTIONS BY ACCIDENT RATE

CO. NO.	SEC. NO.	ROUTE NO.	SECTION DESCRIPTION	SECTION LENGTH	AVERAGE DAILY TRAFFIC	NO. OF ACCIDENTS				NO. OF PEOPLE		AMOUNT OF PROPERTY DAMAGE	TOTAL ECONOMIC LOSS	ACCI-DENT RATE
						PROPERTY DAMAGE	INJURY	FATAL	TOTAL ACCIDENT	INJURED	KILLED			
23	3	MO 6	FAP 16-US87	.3	1911	6	1	1	8	1	1	3540	26540	38.2
			FAS 309											
43	6	US 10	FAP 8-US10N	.1	1741	1	1		2	1		2000	3000	31.5
			GALLATIN CO. LINE											
9	3	US 212	FAS 391	.1	1269	1			1			50	50	21.6
			BROADUS CITY LIMITS											
8	1	US 87	FERGUS CO. LINE	.5	1019	3	1		4	2		2020	4020	21.5
			FAP 45-MONT. 19											
			BROWNING CITY LIMITS											
38	3	US 89	P.T.W.-FAP 1	.1	1425	1			1			800	800	19.2
			HARLOWTON CITY LIMITS											
44	5	MO 6	FAP 45-MONT. 19	.5	1142	3		1	4	3	2	3390	50390	19.2
			FAP 13-US191											
6	14	US 191	YELLOWSTONE PARK	.4	798	1		1	2	1	1	300	23300	17.2
			FAP 19-US10A											
30	6	US 10S	SILVER BOW CO. LINE	.6	2913	8	2		10	2		3510	5510	15.7
			TETON CO. LINE											
31	3	US 89	FAIRFIELD CITY LIMITS	3.0	907	8	7		15	11		9120	20120	15.1
			FAS 244											
23	13	US 87	PETROLEUM CO. LINE	1.2	325	1	1		2	3		1220	4220	14.0
			FAS 401											
51	3	US 10S	WHITEHALL CITY LIMITS	.1	2145	1			1			120	120	12.8

CO. NO.	SEC. NO.	ROUTE NO.	SECTION DESCRIPTION	SECTION LENGTH	AVERAGE DAILY TRAFFIC	NO. OF ACCIDENTS				NO. OF PEOPLE		AMOUNT OF PROPERTY DAMAGE	TOTAL ECONOMIC LOSS	ACCI-DENT RATE
						PROPERTY DAMAGE	INJURY	FATAL	TOTAL ACCIDENT	INJURED	KILLED			
11	11	MO 19	FAS 363	1.1	422	2			2		800	800	11.8	
			MALTA CITY LIMITS											
18	8	US 91	DILLON CITY LIMITS	.1	2490	1			1		690	690	11.0	
			FAP 49-MONT. 41											
47	9	MO 6	FAS 294	1.2	429	2			2		800	800	10.6	
			WHEATLAND CO. LINE											
53	4	MO 6	FAP 53-MONT. 3	5.6	303	6			6		2650	2650	9.7	
			MUSSELSHELL CO. LINE											
24	6	US 2	HARLEM CITY LIMITS	.9	1291	4					2230	2230	9.4	
			FAS 396											
3	9	US 10	BILLINGS CITY LIMITS	.3	10035	8	2		10	2	2700	4700	9.1	
			FAP 16-US87											
54	5	US 10	ALBERTON CITY LIMITS	.8	1533	3	1		4	1	1690	2690	8.9	
			MISSOULA COUNTY LINE											
51	8	MO 1	JEFFERSON CO. LINE	.9	351	1			1		150	150	8.7	
			FAP 2-US10											
46	6	US 10A	GRANITE CO. LINE	4.0	402	5			5		1350	1350	8.5	
			FAP 35-MONT. 38											
3	5	US 10	FAS 305	1.6	7731	32	6		38	12	12650	24650	8.4	
			SOUTHSIDE BY-PASS											
16	2	US 10	FAP 17-US10	.7	4753	9	1		10	1	2960	3960	8.2	
			FAP 20-MONT. 16											

CO NO.	SEC NO.	ROUTE NO.	SECTION DESCRIPTION	SECTION LENGTH	AVERAGE DAILY TRAFFIC	NO. OF ACCIDENTS				NO. OF PEOPLE		AMOUNT OF PROPERTY DAMAGE	TOTAL ECONOMIC LOSS	ACCI-DENT RATE
						PROPERTY DAMAGE	INJURY	FATAL	TOTAL ACCIDENT	INJURED	KILLED			
2	12	US 89	CASCADE CO. LINE	7.4	186	3	1		4	1	1500	2500	8.0	
			NEIHART CITY LIMITS											
2	10	US 89	FAP 15-US87	4.1	931	7	4		11	10	5290	15290	7.9	
			FAS 331											
2	6	US 89	FAP 41-US89	1.0	2864	5	3		8	6	4000	10000	7.7	
			AIR BASE ROAD											
26	1	US 89	PONDERA CO. LINE	16.0	248	3	6	1	10	11	6750	39750	6.9	
			FAS 216											
1	2	US 10S	FAP 3-US91	3.5	4861	27	14		41	21	20130	41130	6.6	
			BREWERY BY PASS											
7	24	MO 40	COLUMBIA FALLS CITY LIMIT	1.7	1729	6	1		7	2	4170	6170	6.5	
			FAP 1-US2											
35	7	US 10A	PLAINS CITY LIMITS	.4	1077	1			1		230	230	6.4	
			FAP 36-MONT. 28											
5	12	MO 33	FAP 24-MONT. 20	18.4	164	3	2	2	7	5	10500	59500	6.4	
			FAS 434 & 435 IN AUGUSTA											
37	5	MO 13	FLAXVILLE CITY LIMITS	6.2	206	1	2		3	3	2690	5690	6.4	
			TOWN OF WHITETAIL											
5	18	MO 20	FAP 9-MONT. 33	7.8	228	4			4		1460	1460	6.2	
			CASCADE CO. LINE											
42	4	MO 7	EKALAKA CITY LIMITS	11.7	228	6			6		1600	1600	6.2	
			FALLON CO. LINE											

CO. NO.	SEC NO.	ROUTE NO.	SECTION DESCRIPTION	SECTION LENGTH	AVERAGE DAILY TRAFFIC	NO. OF ACCIDENTS				NO. OF PEOPLE		AMOUNT OF PROPERTY DAMAGE	TOTAL ECONOMIC LOSS	ACCI-DENT RATE
						PROPERTY DAMAGE	INJURY	FATAL	TOTAL ACCIDENT	INJURED	KILLED			
47	2	US 89	FAS 294	8.0	224	2	2		4	3	1650	4650	6.1	
			FAP 14-MONT. 6											
2	16	MO 20	CASCADE CO. LINE	10.6	212	3	2		5	6	3080	9080	6.1	
			AUGUSTA SPUR MONT. 21											
4	8	US 93	MISSOULA CO. LINE	6.8	1409	18	3		21	5	8220	13220	6.0	
			FAS 412											
20	3	US 2	GLASGOW CITY LIMITS	1.4	2008	3	3		6	3	4400	7400	5.8	
			FAS 247											
2	15	MO 21	CASCADE CO. LINE	5.6	252	2	1		3	1	700	1700	5.8	
			FAP 24-MONT. 20											
13	2	MO 38	BITTERROOT NATL. FOREST	18.0	53	2			2		180	180	5.7	
			GRANITE CO. LINE											
56	3	US 2	TROY CITY LIMITS	2.5	988	3	2		5	2	2100	4100	5.5	
			FAS 202											
38	5	US 2	FAP 3-US89	2.3	1740	8			8		3500	3500	5.5	
			FAP 3-US89											
2	1	US 89	FAP 24-MONT. 20	12.1	663	11	5		16	7	6200	13200	5.5	
			TETON CO. LINE											
30	5	US 10A	FAP 2-US10	4.6	1728	8	8		16	11	7410	18410	5.5	
			FAS 275											
30	11	US 10A	FAP 47-MONT. 48	1.3	4228	8	5		11	5	5250	10250	5.5	
			ANACONDA CITY LIMITS											

CO. NO.	SEC NO.	ROUTE NO.	SECTION DESCRIPTION	SECTION LENGTH	AVERAGE DAILY TRAFFIC	NO. OF ACCIDENTS				NO. OF PEOPLE		AMOUNT OF PROPERTY DAMAGE	TOTAL ECONOMIC LOSS	ACCI-DENT RATE
						PROPERTY DAMAGE	INJURY	FATAL	TOTAL ACCIDENT	INJURED	KILLED			
31	1	MO 33	TETON COUNTY LINE	1.7	300		1		1	2	1200	3200	5.4	
			FAS 408											
30	1	US 10A	ANACONDA CITY LIMITS	17.7	1024	28	6	2	36	8	2	15060	67060	5.4
			GRANITE CO. LINE											
38	12	US 89	P.T.W.-FAP 1	12.0	517	10	2		12	4		4820	8820	5.3
			EAST GLACIER SPUR											
49	7	US 89	FAS 362	24.2	876	31	9	1	41	13	1	32530	67530	5.3
			LIVINGSTON CITY LIMITS											
39	7	MO 7	FALLON CO. LINE	17.1	210	5	2		7	3		1800	4800	5.3
			FAS 322											
8	7	US 87	GRASS RANGE CITY LIMITS	1.0	530		1		1	1		450	1450	5.2
			FAP 15-MONT. 18											
30	4	US 10A	FAS 275	1.4	2650	4	3		7	5		3400	8400	5.2
			FAS 274											
6	20	US 191	TOWN OF KARST KAMP	20.1	469	15	3		18	7		10480	17480	5.2
			FAS 345											
7	9	US 2	GLACIER PARK BOUNDARY	16.8	479	12	3		15	4		4230	8230	5.1
			GLACIER COUNTY LINE											
1	6	US 91	BUTTE CITY LIMITS	3.8	2307	13	3		16	4		8430	12430	5.0
			JEFFERSON CO. LINE											
25	13	MO 1	TOWN OF CAMERON	10.4	367	5	2		7	2		19500	21500	5.0
			ENNIS CITY LIMITS											

CO. NO.	SEC. NO.	ROUTE NO.	SECTION DESCRIPTION	SECTION LENGTH	AVERAGE DAILY TRAFFIC	NO. OF ACCIDENTS				NO. OF PEOPLE		AMOUNT OF PROPERTY DAMAGE	TOTAL ECONOMIC LOSS	ACCI- DENT RATE
						PROPERTY DAMAGE	INJURY	FATAL	TOTAL ACCIDENT	INJURED	KILLED			
34	5	MO 5	FAP 22-MONT. 16	23.4	282	6	6		12	10		11600	21600	5.0
			WESTBY CITY LIMITS											
56	6	US 2	LIBBY CITY LIMITS	27.6	807	34	5	1	40	6	1	13830	41830	4.9
			MANICKE JUNCTION											
38	8	US 2	CUT BANK CITY LIMITS	2.4	1643	6	1		7	1		2550	3550	4.9
			FAS 389											
14	3	US 10	MILES CITY CITY LIMITS	1.3	2575	7	2		6	2		3560	5560	4.9
			FAP 17-US10											
15	12	US 93	RONAN CITY LIMITS	11.6	1355	23	4	1	28	10	1	9130	41130	4.9
			FAP 52-MONT. 35											
9	5	US 212	BROADUS CITY LIMITS	1.5	750	1	1		2	1		960	1960	4.9
			FAS 402											
27	1	MO 23	RICHLAND CO. LINE	16.8	67	2			2			2280	2280	4.9
			CO. RD. TO LAMBERT											
51	12	US 91	BOULDER CITY LIMITS	25.7	870	27	11	1	39	15	1	15330	52330	4.8
			LEWIS & CLARK CO. LINE											
2	19	US 91	CASCADE CO. LINE	16.3	980	19	9		28	15		16200	31200	4.8
			CASCADE CITY LIMITS											
35	1	US 10A	MONTANA-IDAHO LINE	11.6	685	10	4		14	5		6040	11040	4.8
			FAS 202											
10	7	US 310	FAS 308	.9	1303	2			2			1110	1110	4.7
			BRIDGER CITY LIMITS											

CO. NO.	SEC. NO.	ROUTE NO.	SECTION DESCRIPTION	SECTION LENGTH	AVERAGE DAILY TRAFFIC	NO. OF ACCIDENTS				NO. OF PEOPLE		AMOUNT OF PROPERTY DAMAGE	TOTAL ECONOMIC LOSS	ACCI-DENT RATE
						PROPERTY DAMAGE	INJURY	FATAL	TOTAL ACCIDENT	INJURED	KILLED			
46	7	US 10A	FAP 35-MONT. 38 ROAD TO PHILIPSBURG	6.3	461	1	4		5	7		4910	11910	4.7
5	9	US 91	FAS 279 FAP 9-MONT. 33	27.2	1084	33	15	1	49	23	1	27040	72040	4.6
38	9	US 2	FAS 389 TOOLE COUNTY LINE	5.1	1185	7	3		10	5		5070	10070	4.5
18	6	US 91	FAS 324 DILLON CITY LIMITS	21.3	750	20	5	1	26	7	1	26480	55480	4.5
5	19	MO 21	FAP 9-MONT. 33 CASCADE CO. LINE	15.5	156	3	1		4	2		1650	3650	4.5
25	8	MO 34	FAS 357 SHERIDAN CITY LIMITS	9.9	491	6	2		8	2		4000	6000	4.5
46	5	MO 38	GRANITE CO. LINE FAP 19-US10A	28.0	87		4		4	4		1990	5990	4.5
56	4	US 2	FAS 202 LIBBY CITY LIMITS	15.3	1225	21	8	1	30	14	1	10880	46880	4.4
48	5	US 2	FAS 224 NEAR JOPLIN HILL CO. LINE	.8	785	1			1			400	400	4.4
22	10	MO 47	HARDIN CITY LIMITS YELLOWSTONE CO. LINE	22.2	394	10	3	1	14	4	1	6810	32810	4.4
7	4	US 2	KALISPELL CITY LIMITS FAS 206	1.4	6300	9	5		14	8		10520	18520	4.3

CO. NO.	SEC. NO.	ROUTE NO.	SECTION DESCRIPTION	SECTION LENGTH	AVERAGE DAILY TRAFFIC	NO. OF ACCIDENTS				NO. OF PEOPLE		AMOUNT OF PROPERTY DAMAGE	TOTAL ECONOMIC LOSS	ACCI-DENT RATE
						PROPERTY DAMAGE	INJURY	FATAL	TOTAL ACCIDENT	INJURED	KILLED			
38	6	US 2	FAP 3-US89	30.7	961	38	7	1	46	10	1	20690	52690	4.3
			CUT BANK CITY LIMITS											
38	13	US 89	EAST GLACIER SPUR	32.2	498	17	8		25	9		17180	26180	4.3
			FAP 39-MONT. 17											
7	10	US 93	FLATHEAD CO. LINE	11.0	1035	14	4		18	5		8480	13480	4.3
			FAS 208						7					
15	5	US 10A	LAKE COUNTY LINE	.9	716	1			1			500	500	4.3
			FAP 5-US93											
2	14	US 89	NEIHART CITY LIMITS	32.8	233	9	2	1	12	4	1	3330	29330	4.3
			FAP 15-US87											
8	3	US 87	LEWISTOWN SPUR	1.9	1000	1	2		3	3		2740	5740	4.3
			LEWISTOWN CITY LIMITS											
26	8	US 91	FAS 366	3.0	1497	5	2		7	6		2090	8090	4.3
			FAS 216											
5	15	MO 20	LEWIS & CLARK CO. LINE	5.7	333	3			3			710	710	4.3
			TOWN OF LINCOLN											
25	2	MO 41	TWIN BRIDGES CITY LIMITS	14.0	592	9	4		13	6		5560	11560	4.3
			FAS 401											
18	2	MO 43	FAS 278	15.5	124	2	1			2		1280	3280	4.3
			DEERLODGE CO. LINE											
6	21	US 191	FAS 345	6.1	942	9			9			3830	3830	4.3
			FAS 289-291											

CO. NO.	SEC NO.	ROUTE NO.	SECTION DESCRIPTION	SECTION LENGTH	AVERAGE DAILY TRAFFIC	NO. OF ACCIDENTS				NO. OF PEOPLE		AMOUNT OF PROPERTY DAMAGE	TOTAL ECONOMIC LOSS	ACCI-DENT RATE
						PROPERTY DAMAGE	INJURY	FATAL	TOTAL ACCIDENT	INJURED	KILLED			
5	13	MO 33	FAS 434 & 435 IN AUGUSTA	1.3	505			1	1		1	20	22020	4.2
			FAP 24 AUGUSTA SPUR											
44	8	MO 6	FAS 394	6.3	625	2	4		6	6		7150	13150	4.2
			GOLDEN VALLEY CO. LINE											
55	1	MO 18	PETROLEUM CO. LINE	12.3	263	4	1		5	1		1240	2240	4.2
			WINNETT CITY LIMITS											
22	3	US 87	FAS 384	1.7	2302	4	2		6	4		2570	6570	4.2
			HARDIN CITY LIMITS											
5	16	MO 20	TOWN OF LINCOLN	11.8	333	5	1		6	2		1850	3850	4.2
			FAS 279											
51	1	US 10S	JEFFERSON CO. LINE	8.7	1628	15	4	2	21	8	3	13610	87610	4.1
			FAP 29-MONT. 41											
6	10	US 10	FAS 411	2.4	3864	12	2		14	2		6630	8630	4.1
			BOZEMAN CITY LIMITS											
5	11	MO 33	FAP 3-US91	23.0	202	6		1	7	2	2	3200	49200	4.1
			FAP 24-MONT. 20											
47	7	US 89	FAP 14-MONT. 6	28.5	163	7			7			2940	2940	4.1
			CASCADE CO. LINE											
27	3	MO 23S	FAP 20-MONT. 16	7.6	264	2		1	3		1	1860	23860	4.1
			MONT.-N.DAK. LINE											
6	23	US 191	FAS 345	2.8	1673	6	1		7	7		3480	10480	4.1
			BOZEMAN CITY LIMITS											

CO. NO.	SEC. NO.	ROUTE NO.	SECTION	DESCRIPTION	SECTION LENGTH	AVERAGE DAILY TRAFFIC	NO. OF ACCIDENTS				NO. OF PEOPLE		AMOUNT OF PROPERTY DAMAGE	TOTAL ECONOMIC LOSS	ACCI-DENT RATE
							PROPERTY DAMAGE	INJURY	FATAL	TOTAL ACCIDENT	INJURED	KILLED			
6	5	US 10	FAS 286		8.4	1892	16	6	1	23	9	1	11700	42700	4.0
			MANHATTAN CITY LIMITS												
			BOZEMAN CITY LIMITS												
6	12	US 10	PARK COUNTY LINE		12.1	2259	28	11	1	40	21	1	28240	71240	4.0
			CASCADE CITY LIMITS												
2	21	US 91	FAS 330		14.2	1249	14	10	2	26	25	2	15870	84870	4.0
			FAP 14-MONT. 6												
44	10	MO 19	JUDITH GAP CITY LIMITS		17.5	544	11	1	2	14	2	2	8100	54100	4.0
			FAS 289-291												
6	22	US 191	FAS 345		3.9	1412	6	2		8	3		3040	6040	4.0
			MANICKE JUNCTION												
56	7	US 2	FLATHEAD COUNTY LINE		19.7	605	15	2		17	2		6520	8520	3.9
			FAS 247												
20	4	US 2	NASHUA CITY LIMITS		11.7	1134	14	5		19	8		9440	17440	3.9
			POPLAR CITY LIMITS												
17	6	US 2	FAS 251		5.3	1189	6	2	1	9	3	3	4540	73540	3.9
			FALLON COUNTY LINE												
39	1	US 12	FAS 320		6.1	459	4			4			2150	2150	3.9
			HELENA CITY LIMITS												
5	8	US 91	FAS 279		6.1	1841	13	2	1	16	6	1	11020	39020	3.9
			EAST GLACIER SPUR												
38	2	US 2	PTW NEAR BROWNING		11.3	711	10	1		11	1		4050	5050	3.8

CO NO.	SEC. NO.	ROUTE NO.	SECTION DESCRIPTION	SECTION LENGTH	AVERAGE DAILY TRAFFIC	NO. OF ACCIDENTS				NO. OF PEOPLE		AMOUNT OF PROPERTY DAMAGE	TOTAL ECONOMIC LOSS	ACCI-DENT RATE
						PROPERTY DAMAGE	INJURY	FATAL	TOTAL ACCIDENT	INJURED	KILLED			
11	1	US 2	PHILLIPS COUNTY LINE	7.4	691	4	3		7	5	4840	9840	3.8	
			DODSON CITY LIMITS											
11	4	US 2	FAS 363	9.1	1108	10	3	1	14	4	1	5750	31750	3.8
			MALTA CITY LIMITS											
4	6	US 10	FAP 24-MONT. 20	12.1	2453	34	7		41	11		17470	28470	3.8
			TOWN OF CLINTON											
49	4	US 10	FAP 11-US89	13.6	1712	23	9		32	12		19070	31070	3.8
			SWEETGRASS CO. LINE											
2	25	US 87	FAP 40	3.4	1718	5	2	1	8	3	1	5560	30560	3.8
			FAS 225											
56	8	MO 37	CITY LIMITS OF LIBBY	55.6	196	13	2		15	4		5870	9870	3.8
			TOWN OF REXFORD											
35	10	MO 28	FAP 6-US10A	16.3	402	6	3		9	4		3160	7160	3.8
			FAS 382											
15	7	US 93	FAP 6-US10A	5.1	1464	6	2	2	10	3	2	5120	52120	3.7
			ST.IGNATIUS CITY LIMITS											
56	10	US 93	EUREKA CITY LIMITS	7.9	186	2			2			500	500	3.7
			MONTANA-CANADA LINE											
28	5	US 10N	FAS 272	14.9	1033	15	6		21	8		9430	17430	3.7
			LEWIS & CLARK CO. LINE											
5	1	US 10N	LEWIS & CLARK CO. LINE	13.0	1182	13	8		21	10		18600	28600	3.7
			FAS 356											

CO. NO.	SEC. NO.	ROUTE NO.	SECTION DESCRIPTION	SECTION LENGTH	AVERAGE DAILY TRAFFIC	NO. OF ACCIDENTS				NO. OF PEOPLE		AMOUNT OF PROPERTY DAMAGE	TOTAL ECONOMIC LOSS	ACCI-DENT RATE
						PROPERTY DAMAGE	INJURY	FATAL	TOTAL ACCIDENT	INJURED	KILLED			
19	3	US 87	FAS 223 & 230	2.6	574	2			2			650	650	3.7
			FAS 387											
			FAS 348											
46	10	US 10A	TOWN OF MAXVILLE	11.6	315	3	2		5	3		3320	6320	3.7
			AUGUSTA SPUR MONT. 21											
2	17	MO 20	FAP 3-US89	12.3	783	11	2		13	3		4110	7110	3.7
			FAS 382											
35	11	MO 28	HOT SPRINGS SPUR	2.7	552	1		1	2	1		3300	25300	3.7
			MARION JUNCTION											
7	2	US 2	KALISPELL CITY LIMITS	19.9	1004	18	8		26	8		11200	19200	3.6
			WEST GLACIER SPUR											
7	8	US 2	GLACIER PARK BOUNDARY	27.8	499	13	5		18	6		10750	16750	3.6
			BRIDGER CITY LIMITS											
10	9	US 310	FROMBERG CITY LIMITS	6.5	1271	7	4		11	7		6700	13700	3.6
			FAP 45-MONT. 19											
44	6	MO 6	FAS 297	15.3	701	11	2	1	14	2	1	6930	30930	3.6
			TOWN OF SUMATRA											
29	2	MO 6	TOWN OF INGOMAR	9.0	169	2			2			500	500	3.6
			TOWN OF ASHLAND											
29	11	MO 8	POWDER RIVER CO. LINE	2.0	376	1			1			800	800	3.6
			GLACIER COUNTY LINE											
38	1	US 2	EAST GLACIER SPUR	11.3	553	7	1		8	1		4990	5990	3.5

CO. NO.	SEC. NO.	ROUTE NO.	SECTION DESCRIPTION	SECTION LENGTH	AVERAGE DAILY TRAFFIC	NO. OF ACCIDENTS				NO. OF PEOPLE		AMOUNT OF PROPERTY DAMAGE	TOTAL ECONOMIC LOSS	ACCI-DENT RATE
						PROPERTY DAMAGE	INJURY	FATAL	TOTAL ACCIDENT	INJURED	KILLED			
1	14	US 10S	BUTTE CITY LIMITS	1.5	5247	3	7		10	27		7140	34140	3.5
			FAS 392											
18	4	US 91	MONT. IDAHO LINE	15.2	516	7	3		10	4		7910	11910	3.5
			LIMA CITY LIMITS											
51	10	US 91	JEFFERSON CO. LINE	30.3	981	30	6	2	38	12	2	19150	75150	3.5
			BOULDER CITY LIMITS											
36	4	US 87	HOBSON CITY LIMITS	5.5	991	5	2		7	3		4180	7180	3.5
			FERGUS CO. LINE											
4	14	MO 20	FAS 209	3.8	416	2			2			140	140	3.5
			POWELL CO. LINE											
30	12	MO 48	FAP 19-US10A	6.2	1004	5	3		8	4		8730	12730	3.5
			FAP 2-US10											
29	5	US 10	FAS 315	6.1	1328	7	3		10	7		5120	12120	3.4
			FORSYTH CITY LIMITS											
7	16	US 93	WHITEFISH CITY LIMITS	11.1	727	6	4		10	4		8240	12240	3.4
			FAS 424											
5	5	US 10N	HELENA CITY LIMITS	3.1	3335	3	5		13	9		4900	13900	3.4
			EAST HELENA CITY LIMITS											
6	1	MO 1	GALLATIN CO. LINE	2.3	350		1		1	1		600	1600	3.4
			JEFFERSON CO. LINE											
44	2	MO 6	FAS 296	11.3	796	9	1	1	11	1	1	4320	27320	3.4
			HARLOWTON CITY LIMITS											

CO. NO.	SEC. NO.	ROUTE NO.	SECTION DESCRIPTION	SECTION LENGTH	AVERAGE DAILY TRAFFIC	NO. OF ACCIDENTS				NO. OF PEOPLE		AMOUNT OF PROPERTY DAMAGE	TOTAL ECONOMIC LOSS	ACCI-DENT RATE
						PROPERTY DAMAGE	INJURY	FATAL	TOTAL ACCIDENT	INJURED	KILLED			
7	7	US 2	FAP 38-MONT. 40	14.9	1692	20	9	1	30	11	1	14000	47000	3.3
			WEST GLACIER SPUR											
1	1	US 10S	SILVER BOW CO. LINE	8.6	2967	21	8	2	31	14	3	20360	100360	3.3
			FAP 3-US91											
1	12	US 10S	FAS 393	8.9	2437	16	9	1	26	13	1	17930	52930	3.3
			JEFFERSON CO. LINE											
5	4	US 91	LEWIS & CLARK CO. LINE	2.1	1196	1	2		3	2		400	2400	3.3
			HELENA CITY LIMITS											
5	10	US 91	FAP 9-MONT. 33	15.1	948	14	2	1	17	2	1	15670	39670	3.3
			CASCADE CO. LINE											
2	22	US 91	FAS 330	9.3	1429	11	5		16	13		8180	21180	3.3
			GT. FALLS CITY LIMITS											
47	1	US 89	MEAGHER CO. LINE	11.6	145	1	1		2	1		1050	2050	3.3
			FAS 294											
6	13	US 191	MONTANA-IDAHO LINE	9.4	791	5	4		9	8		8400	16400	3.3
			FAP 13-US191											
23	1	MO 6	MUSSELSHELL CO. LINE	11.0	304	2	2		4	3		2090	5090	3.3
			FAS 381											
10	1	US 12	COOKE CITY HIGHWAY	8.7	378	4			4			1600	1600	3.3
			RED LODGE CITY LIMITS											
48	4	US 2	CHESTER CITY LIMITS	9.2	832	8	1		9	1		2690	3690	3.2
			FAS 224 NEAR JOPLIN											

CO. NO.	SEC. NO.	ROUTE NO.	SECTION DESCRIPTION	SECTION LENGTH	AVERAGE DAILY TRAFFIC	NO. OF ACCIDENTS				NO. OF PEOPLE		AMOUNT OF PROPERTY DAMAGE	TOTAL ECONOMIC LOSS	ACCI-DENT RATE
						PROPERTY DAMAGE	INJURY	FATAL	TOTAL ACCIDENT	INJURED	KILLED			
54	1	US 10	MONTANA-IDAHO LINE	46.6	1334	53	19		72	26		51160	77160	3.2
			SUPERIOR CITY LIMITS											
3	4	US 10	LAUREL CITY LIMITS	11.5	5522	62	12	1	75	22	1	35230	79230	3.2
			FAS 305											
26	2	US 89	FAS 216	5.0	340	2			2			500	500	3.2
			GLACIER CO. LINE											
10	6	US 310	MONTANA-WYOMING LINE	24.8	727	13	6	2	21	12	3	16540	94540	3.2
			FAS 308											
15	17	US 93	FAS 352	10.3	587	6	1		7	1		3490	4490	3.2
			FLATHEAD CO. LINE											
30	3	US 10A	FAS 274	1.4	3035	3	2		5	2		5450	7450	3.2
			FAP 47-MONT. 48											
17	3	US 2	WOLF POINT CITY LIMITS	6.2	1269	7	2		9	3		5580	8580	3.1
			FAP 32-MONT. 13											
17	9	US 2	BROCKTON CITY LIMITS	18.1	737	12	3		15	6		10120	16120	3.1
			CULBERTSON CITY LIMITS											
4	2	US 10	FAS 263	6.9	1692	9	3	1	13	10	1	13280	45280	3.1
			FAP 5-US93											
14	4	US 12	FAP 17-US10	13.7	515	7	1		8	2		3250	5250	3.1
			FAS 333											
4	12	US 10A	FAP 2-US10	15.2	1472	18	7		25	11		11600	22600	3.1
			LAKE COUNTY LINE											

CO. NO.	SEC. NO.	ROUTE NO.	SECTION DESCRIPTION	SECTION LENGTH	AVERAGE DAILY TRAFFIC	NO. OF ACCIDENTS				NO. OF PEOPLE		AMOUNT OF PROPERTY DAMAGE	TOTAL ECONOMIC LOSS	ACCI-DENT RATE
						PROPERTY DAMAGE	INJURY	FATAL	TOTAL ACCIDENT	INJURED	KILLED			
7	14	US 93	FAP 38-MONT. 40	1.4	2491	3	1		4	1		680	1680	3.1
			WHITEFISH CITY LIMITS											
23	4	MO 6	FAS 309	.7	2500	1	1		2	1		60	1060	3.1
			ROUNDUP CITY LIMITS											
2	11	US 87	FAP 11-US89	7.2	852	4	3		7	3		2530	5530	3.1
			JUDITH BASIN CO. LINE											
36	1	US 87	JUDITH BASIN CO. LINE	29.6	737	21	4		25	4		12280	16280	3.1
			FAS 230											
8	6	US 87	LEWISTOWN CITY LIMITS	29.5	662	14	8		22	10		10340	20340	3.1
			FAP 16-US87											
16	6	MO 18	DAWSON CO. LINE	15.0	406	4	3		7	4		3750	7750	3.1
			TOWN OF LINDSAY											
16	3	US 10	FAP 20-MONT. 16	.8	7623	7			7			1070	1070	3.1
			GLENDIVE CITY LIMITS											
3	18	US 87	YELLOWSTONE CO. LINE	25.9	1628	35	12		47	14		33360	47360	3.1
			FAP 2-US10											
17	16	MO 16	ROOSEVELT CO. LINE	3.4	515	1	1		2	1		1300	2300	3.1
			FROID CITY LIMITS											
42	1	US 212	CARTER CO. LINE	35.4	273	9	2		11	4		10710	14710	3.1
			FAS 323											
15	2	MO 28	LAKE CO. LINE	6.6	270	1	1		2	1		800	1800	3.1
			FAP 5-US93											

CO. NO.	SEC. NO.	ROUTE NO.	SECTION DESCRIPTION	SECTION LENGTH	AVERAGE DAILY TRAFFIC	NO. OF ACCIDENTS				NO. OF PEOPLE		AMOUNT OF PROPERTY DAMAGE	TOTAL ECONOMIC LOSS	ACCI-DENT RATE
						PROPERTY DAMAGE	INJURY	FATAL	TOTAL ACCIDENT	INJURED	KILLED			
40	5	MO 19	FAS 371 WHEATLAND CO. LINE	8.2	217	2			2			470	470	3.1
18	10	MO 41	FAP 3-US91 MADISON CO. LINE	13.7	448	4	3		7	3		34670	37670	3.1
46	4	US 10	FAS 271 POWELL COUNTY LINE	4.7	2105	7	4		11	6		6030	12030	3.0
3	10	US 10	FAP 16-US87 FAP 16-US87	3.5	6028	21	2		23	2		6550	8550	3.0
19	4	US 87	FAS 387 BIG SANDY CITY LIMITS	35.9	691	20	7		27	11		18550	29550	3.0
10	5	US 12	JOLIET CITY LIMITS FAP 4-US310	5.3	852	3	2		5	2		1970	3970	3.0
20	8	MO 24	VALLEY CO. LINE GLASGOW CITY LIMITS	19.2	477	6	4		10	10		5510	15510	3.0
44	9	MO 19	WHEATLAND CO. LINE HARLOWTON CITY LIMITS	15.6	290	4	1		5	2		1680	3680	3.0
25	3	MO 41	MADISON CO. LINE TWIN BRIDGES CITY LIMITS	13.2	409	6			6			1860	1860	3.0
14	1	US 10	CUSTER CO. LINE MILES CITY CITY LIMITS	18.6	1316	16	8	2	26	16	3	32770	114770	2.9
14	5	US 12	FAS 333 FALLON COUNTY LINE	33.8	455	11	5		16	7		4990	11990	2.9

CO. NO.	SEC. NO.	ROUTE NO.	SECTION DESCRIPTION	SECTION LENGTH	AVERAGE DAILY TRAFFIC	NO. OF ACCIDENTS				NO. OF PEOPLE		AMOUNT OF PROPERTY DAMAGE	TOTAL ECONOMIC LOSS	ACCI- OENT RATE
						PROPERTY DAMAGE	INJURY	FATAL	TOTAL ACCIDENT	INJURED	KILLED			
38	5	US 89	FAP 1-US2 BROWNING CITY LIMITS	.9	2089	1	1		2	3		550	3550	2.9
15	6	US 10A	LAKE COUNTY LINE FAP 6-US10A	12.4	1618	14	7		21	10		9150	19150	2.9
35	5	US 10A	THOMPSON FALLS CITY LIMIT PLAINS CITY LIMITS	24.2	660	11	5	1	17	8	1	8100	38100	2.9
13	3	US 93	MONTANA-IDAHO LINE DARBY CITY LIMITS	30.5	435	9	5		14	7		4850	11850	2.9
53	3	MO 6	RYEGATE CITY LIMITS FAP 53-MONT. 3	15.6	718	7	4	1	12	8	1	5820	35820	2.9
34	10	MO 16	FAP 30-MONT. 5 FAS 258	12.5	675	5	4		9	6		6530	12530	2.9
39	10	MO 7	FAS 336 WIBAUX CO. LINE	5.0	192	1			1			30	30	2.9
6	17	US 191	FAP 13-MONT. 1 YELLOWSTONE PARK BOUNDARY	2.5	383	1			1			280	280	2.9
28	8	US 10S	FAS 407 DEER LODGE CITY LIMITS	5.7	1722	9	1		10	1		3770	4770	2.8
6	9	US 10	BELGRADE CITY LIMITS FAS 411	6.1	3060	13	6		19	8		7180	15180	2.8
22	9	US 87	FAS 463 NEAR LODGEGRASS FAP 37-MONT. 8	19.2	1018	9	11		20	14		65700	79700	2.8

CO. NO.	SEC. NO.	ROUTE NO.	SECTION DESCRIPTION	SECTION LENGTH	AVERAGE DAILY TRAFFIC	NO. OF ACCIDENTS				NO. OF PEOPLE		AMOUNT OF PROPERTY DAMAGE	TOTAL ECONOMIC LOSS	ACCI-DENT RATE
						PROPERTY DAMAGE	INJURY	FATAL	TOTAL ACCIDENT	INJURED	KILLED			
27	5	MO 16	FAP 51-FAP 26	1.8	2140	3	1		4	1	2100	3100	2.8	
			SIDNEY CITY LIMITS											
			CONRAD CITY LIMITS											
26	7	US 91	FAS 366	6.0	1654	8	2		10	4	2710	6710	2.8	
			SHERIDAN CO. LINE											
34	1	MO 5	FAS 374	12.4	391	2	3		5	3	5750	8750	2.8	
			BAKER CITY LIMITS											
39	9	MO 7	FAS 336	13.7	284	3	1		4	1	4140	5140	2.8	
			VIRGINIA CITY CITY LIMITS											
25	9	MO 34	FAS 357	8.4	346	3			3		830	830	2.8	
			FAP 32-MONT. 13											
17	4	US 2	POPLAR CITY LIMITS	14.9	1155	12	4	1	17	6	6640	34640	2.7	
			SUPERIOR CITY LIMITS											
54	3	US 10	ALBERTON CITY LIMITS	27.4	1462	30	10		40	12	37590	49590	2.7	
			MISSOULA CITY LIMITS											
4	5	US 10	FAP 24-MONT. 20	6.0	4987	17	12	1	30	21	13550	56550	2.7	
			FAS 281											
51	6	US 10S	FAP 13-MONT. 1	13.7	1244	13	2	2	17	4	9430	57430	2.7	
			YELLOWSTONE CO. LINE											
3	1	US 10	LAUREL CITY LIMITS	5.1	2347	10	2		12	4	6380	10380	2.7	
			SILVER BOW CO. LINE											
1	9	US 91	FAP 46-MONT. 43	10.0	702	2	5		7	8	4990	12990	2.7	

CO. NO.	SEC. NO.	ROUTE NO.	SECTION DESCRIPTION	SECTION LENGTH	AVERAGE DAILY TRAFFIC	NO. OF ACCIDENTS				NO. OF PEOPLE		AMOUNT OF PROPERTY DAMAGE	TOTAL ECONOMIC LOSS	ACCI-DENT RATE
						PROPERTY DAMAGE	INJURY	FATAL	TOTAL ACCIDENT	INJURED	KILLED			
31	5	US 89	FAIRFIELD CITY LIMITS	16.5	549	7	2		9	2		2700	4700	2.7
			CHOTEAU CITY LIMITS											
13	8	US 93	HAMILTON CITY LIMITS	11.0	1269	8	6		14	6		6700	12700	2.7
			FAS 370											
2	8	US 89	FAS 331	12.5	1377	14	2	1	17	5	1	8320	35320	2.7
			FAS 227 & 228											
41	2	MO 18	FAS 253	11.0	371	1	1	2	4	2	2	1870	47870	2.7
			CIRCLE CITY LIMITS											
16	8	MO 16	FAP 15-US10	3.7	1397	3	2		5	2		4820	6820	2.7
			FAS 254											
9	7	US 212	FAS 319	18.5	272	3	1	1	5	3	1	2250	27250	2.7
			CARTER CO. LINE											
17	20	MO 13	FAP 1-US2	31.1	263	4	3	1	8	4	1	7550	33550	2.7
			DANIELS CO. LINE											
29	10	MO 8	TOWN OF LAMEDEER	20.4	301	3	1	2	6	2	2	9680	55680	2.7
			TOWN OF ASHLAND											
8	15	MO 19	TOWN OF ROY	7.6	135	1			1			700	700	2.7
			FAP 16											
1	8	MO 43	SILVER BOW CO. LINE	3.3	312	1			1			280	280	2.7
			FAP 3-US91											
15	3	MO 35	FAP 5-US93	28.2	654	12	6		18	8		9490	17490	2.7
			FLATHEAD CO. LINE											

CO. NO.	SEC. NO.	ROUTE NO.	SECTION DESCRIPTION	SECTION LENGTH	AVERAGE DAILY TRAFFIC	NO. OF ACCIDENTS				NO. OF PEOPLE		AMOUNT OF PROPERTY DAMAGE	TOTAL ECONOMIC LOSS	ACCI-DENT RATE
						PROPERTY DAMAGE	INJURY	FATAL	TOTAL ACCIDENT	INJURED	KILLED			
40	1	US 10	SWEETGRASS CO. LINE	14.4	1440	12	7	1	20	14	1	13810	49810	2.6
			BIG TIMBER CITY LIMITS											
7	17	US 93	FAS 424	17.7	360	4	2		6	3		1870	4870	2.6
			LINCOLN CO. LINE											
11	10	MO 19	CO. RD. TO DODSON	33.1	127	4			4			1950	1950	2.6
			FAS 363											
14	6	US 212	FAS 332	38.4	354	12	1		13	2		5600	7600	2.6
			POWDER RIVER CO. LINE											
10	3	US 12	RED LODGE CITY LIMITS	25.1	662	12	4		16	5		7000	12000	2.6
			JOLIET CITY LIMITS											
17	1	US 2	ROOSEVELT CO. LINE	9.3	1171	7	2	2	10	14	1	8520	44520	2.5
			WOLF POINT CITY LIMITS											
28	6	US 10S	DEER LODGE CITY LIMITS	8.6	2126	12	5		17	8		13470	21470	2.5
			DEER LODGE CO. LINE											
40	3	US 10	BIG TIMBER CITY LIMITS	22.0	1183	16	8		24	14		19480	33480	2.5
			STILLWATER COUNTY LINE											
5	14	MO 33	FAP 24 AUGUSTA SPUR	3.3	328	1			1			100	100	2.5
			TETON COUNTY LINE											
6	16	MO 1	FAP 50-US191	15.8	282	3	1		4	1		1750	2750	2.5
			MADISON CO. LINE											
34	2	MO 5	FAS 374	10.9	612	4	1	1	6	2	2	6310	52310	2.5
			PLENTYWOOD CITY LIMITS											

CO. NO.	SEC. NO.	ROUTE NO.	SECTION DESCRIPTION	SECTION LENGTH	AVERAGE DAILY TRAFFIC	NO. OF ACCIDENTS				NO. OF PEOPLE		AMOUNT OF PROPERTY DAMAGE	TOTAL ECONOMIC LOSS	ACCI-DENT RATE
						PROPERTY DAMAGE	INJURY	FATAL	TOTAL ACCIDENT	INJURED	KILLED			
42	2	US 212	FAS 323	2.9	373	1			1		110	110	2.5	
			MONTANA-WYOMING LINE											
17	17	MO 13W	FAP 32-MONT. 13	5.5	798	3	1		4	1	1170	2170	2.5	
			WOLF POINT CITY LIMITS											
29	9	MO 8	ROSEBUD CO. LINE	3.3	332	1			1		200	200	2.5	
			TOWN OF LAMEDEER											
7	1	US 2	FLATHEAD COUNTY LINE	20.1	629	6	4	1	11	12	5350	39350	2.4	
			MARION JUNCTION											
			TOWN OF CLINTON											
4	7	US 10	GRANITE COUNTY LINE	8.5	2026	13	2		15	2	10430	12430	2.4	
			GT. FALLS CITY LIMITS											
2	3	US 91	FAP 21-US91	9.4	3552	19	10		29	16	17340	33340	2.4	
			FAS 212											
15	10	US 93	RONAN CITY LIMITS	4.5	1517	2	4		6	4	1670	5670	2.4	
			FAS 412											
4	9	US 93	FAS 390-FAP 7 SPUR	9.2	2840	22	1		23	2	6630	8630	2.4	
			HILL CO. LINE											
12	6	US 87	FAP 1-US2	22.0	788	12	3		15	6	22170	28170	2.4	
			FLATHEAD CO. LINE											
7	26	MO 28	LAKE CO. LINE	8.5	274	1	1		2	1	2250	3250	2.4	
			FAP 16-US87											
22	5	MO 8	TOWN OF BUSBY	25.6	308	6	1		7	1	8300	9300	2.4	

CO. NO.	SEC. NO.	ROUTE NO.	SECTION DESCRIPTION	SECTION LENGTH	AVERAGE DAILY TRAFFIC	NO. OF ACCIDENTS				NO. OF PEOPLE		AMOUNT OF PROPERTY DAMAGE	TOTAL ECONOMIC LOSS	ACCI-DENT RATE
						PROPERTY DAMAGE	INJURY	FATAL	TOTAL ACCIDENT	INJURED	KILLED			
24	7	US 2	FAS 396 PHILLIPS COUNTY LINE	20.1	775	10	3		13	6		11260	17260	2.3
6	4	US 10	THREE FORKS CITY LIMITS FAS 286	2.5	1909	3	1		4	1		1250	2250	2.3
29	7	US 10	FORSYTH CITY LIMITS CUSTER CO. LINE	25.3	1375	21	7	1	29	11	1	15870	48870	2.3
39	2	US 12	FAS 320 PLEVNA CITY LIMITS	12.4	489	4	1		5	2		1290	3290	2.3
35	8	US 10A	FAP 36-MONT. 28 FAS 382	18.8	498	6	2		6	2		3380	5380	2.3
4	10	US 93	FAS 390-FAP 7 SPUR MISSOULA CITY LIMITS	.4	5850	2			2			150	150	2.3
28	4	US 10N	FAS 407 FAS 272	9.3	1157	7	2		9	2		6220	8220	2.3
49	11	US 89	FAS 339 MEAGHER CO. LINE	14.2	171	1	1		2	1		650	1650	2.3
8	2	US 87	FAP 45-MONT. 19 LEWISTOWN SPUR	14.3	1180	8	4	2	14	8	2	6860	58860	2.3
50	5	MO 18	JORDAN CITY LIMITS MCCONE CO. LINE	35.6	200	6			6			4070	4070	2.3
16	5	US 10	GLENDIVE CITY LIMITS WIBAUX CO. LINE	20.2	1073	12	5	1	18	8	1	10800	40800	2.3

CO. NO.	SEC. NO.	ROUTE NO.	SECTION DESCRIPTION	SECTION LENGTH	AVERAGE DAILY TRAFFIC	NO. OF ACCIDENTS				NO. OF PEOPLE		AMOUNT OF PROPERTY DAMAGE	TOTAL ECONOMIC LOSS	ACCI-DENT RATE
						PROPERTY DAMAGE	INJURY	FATAL	TOTAL ACCIDENT	INJURED	KILLED			
8	16	US 87	FERGUS CO. LINE	18.0	325	3	2		5	3		3550	6550	2.3
			GRASS RANGE CITY LIMITS											
			CULBERTSON CITY LIMITS											
17	13	MO 16	RICHLAND CO. LINE	2.4	486	1			1			750	750	2.3
			RICHLAND CO. LINE											
27	10	MO 16	FAS 201	21.0	400	6	1		7	1		3020	4020	2.3
			FAP 2-US10											
4	13	MO 20	FAS 209	31.8	793	13	8		21	10		10950	20950	2.3
			FLATHEAD CO. LINE											
7	26	MO 35	FAS 209	3.2	755	1	1		2	1		2250	3250	2.3
			FAS 208											
7	20	MO 35	FAP 1-US2	11.6	611	6			6			1570	1570	2.3
			BROADVIEW CITY LIMITS											
3	25	MO 3	GOLDEN VALLEY CO. LINE	2.2	552		1		1	1		660	1660	2.3
			MONTANA-IDAHO LINE											
56	1	US 2	TROY CITY LIMITS	13.9	726	5	1	2	6	4	2	8470	56470	2.2
			NASHUA CITY LIMITS											
20	6	US 2	ROOSEVELT CO. LINE	25.2	939	14	4	1	19	9	1	11890	42890	2.2
			FAS 392											
1	13	US 10S	FAS 393	.8	4593	2	1		3	1		1300	2300	2.2
			FAS 306											
32	2	US 10	COLUMBUS CITY LIMITS	.7	1747	1			1			250	250	2.2

CO. NO.	SEC. NO.	ROUTE NO.	SECTION DESCRIPTION	SECTION LENGTH	AVERAGE DAILY TRAFFIC	NO. OF ACCIDENTS				NO. OF PEOPLE		AMOUNT OF PROPERTY DAMAGE	TOTAL ECONOMIC LOSS	ACCI-DENT RATE
						PROPERTY DAMAGE	INJURY	FATAL	TOTAL ACCIDENT	INJURED	KILLED			
2	2	US 89	FAP 21-US91	7.6	1649	6	3	1	10	7	1	3810	32810	2.2
			FAP 24-MONT. 20											
31	7	US 89	CHOTEAU CITY LIMITS	20.8	480	5	3		8	4		2940	6940	2.2
			FAS 219											
7	11	US 93	FAS 208	5.5	2496	9	2		11	4		4280	8280	2.2
			FAS 207 & FAS 317											
35	9	US 10A	FAS 382	19.8	573	2	6	1	9	8	1	6100	36100	2.2
			LAKE COUNTY LINE											
49	6	US 89	GARDINER	30.9	517	12	1		13	1		3640	4640	2.2
			FAS 362											
22	1	US 87	HARDIN CITY LIMITS	22.2	1131	15	4	1	20	8	1	9520	39520	2.2
			YELLOWSTONE CO. LINE											
27	4	MO 16	RICHLAND CO. LINE	26.9	840	13	3	2	18	3	2	10890	57890	2.2
			FAP 51-FAP 26											
21	4	US 91	TOOLE CO. LINE	8.7	1166	5	2	1	8	2	2	95220	141220	2.2
			SHELBY CITY LIMITS											
39	8	MO 7	FAS 322	5.6	454	2			2			540	540	2.2
			BAKER CITY LIMITS											
21	1	US 2	TOOLE COUNTY LINE	15.5	1155	14			14			6420	6420	2.1
			SHELBY CITY LIMITS											
11	8	US 2	SACO CITY LIMITS	1.5	865			1	1	2	2	1300	47300	2.1
			VALLEY CO. LINE											

CO. NO.	SEC. NO.	ROUTE NO.	SECTION DESCRIPTION	SECTION LENGTH	AVERAGE DAILY TRAFFIC	NO. OF ACCIDENTS				NO. OF PEOPLE		AMOUNT OF PROPERTY DAMAGE	TOTAL ECONOMIC LOSS	ACCI-DENT RATE
						PROPERTY DAMAGE	INJURY	FATAL	TOTAL ACCIDENT	INJURED	KILLED			
46	1	US 10	GRANITE COUNTY LINE	23.1	2063	27	10		37	17		25810	42810	2.1
			DRUMMOND CITY LIMITS											
			LIMA CITY LIMITS											
18	5	US 91	FAS 324	26.6	551	7	3	1	11	4	2	5830	53830	2.1
			ST.IGNATIUS CITY LIMITS											
15	9	US 93	FAS 212	9.3	1424	7	3		10	4		9470	13470	2.1
			MCCONE CO. LINE											
41	1	MO 18	FAS 253	19.0	206	3			3			980	980	2.1
			MUSSELSHELL CO. LINE											
23	10	US 87	TOWN OF KLEIN	22.5	652	9	2		11	2		4880	6880	2.1
			TOWN OF MAXVILLE											
46	11	US 10A	DRUMMOND CITY LIMITS	13.9	378	3	1		4	1		2770	3770	2.1
			FAS 219											
26	5	US 91	CONRAD CITY LIMITS	.6	2217			1	1		1	900	22900	2.1
			FAP 5-US93											
7	21	MO 40	FAS 206	4.6	1391	4	1		5	1		1340	2340	2.1
			PARK COUNTY LINE											
49	1	US 10	LIVINGSTON CITY LIMITS	10.8	2075	13	3		16	4		11160	15160	2.0
			STILLWATER COUNTY LINE											
32	1	US 10	FAS 306	16.9	1363	11	6		17	7		9780	16780	2.0
			COLUMBUS CITY LIMITS											
32	4	US 10	YELLOWSTONE CO. LINE	20.3	1653	17	6	1	24	9	1	22650	53650	2.0

CO NO.	SEC NO.	ROUTE NO.	SECTION DESCRIPTION	SECTION LENGTH	AVERAGE DAILY TRAFFIC	NO. OF ACCIDENTS				NO. OF PEOPLE		AMOUNT OF PROPERTY DAMAGE	TOTAL ECONOMIC LOSS	ACCI-DENT RATE
						PROPERTY DAMAGE	INJURY	FATAL	TOTAL ACCIDENT	INJURED	KILLED			
1	10	US 91	FAP 46-MONT. 43	19.5	835	8	4		12	5		7540	12540	2.0
			FAP 2-US10											
2	7	US 89	FAS 227 & 228	3.0	2241	4	1		5	1		1250	2250	2.0
			FAP 41-US89											
22	4	US 87	FAP 37-MONT. 8	12.7	1633	12	3		15	5		34880	39880	2.0
			FAS 384											
21	6	US 91	FAS 215 & 410	9.9	959	6	1		7	1		1810	2810	2.0
			SUNBURST CITY LIMITS											
7	22	MO 40	FAS 206	2.0	2098	1	2		3	3		2000	5000	2.0
			COLUMBIA FALLS CITY LIMIT											
7	18	MO 35	FAS 209	2.4	1136	2			2			240	240	2.0
			FAS 208											
7	5	US 2	FAS 206	5.4	2179	6	2		8	2		3870	5870	1.9
			FAP 52-MONT. 35											
24	4	US 2	FAS 325	20.0	1168	12	3	1	16	5	1	7450	34450	1.9
			HARLEM CITY LIMITS											
11	6	US 2	MALTA CITY LIMITS	26.9	843	8	8		16	10		12930	22930	1.9
			SACO CITY LIMITS											
20	1	US 2	VALLEY CO. LINE	40.5	955	16	10	1	27	15	1	18040	55040	1.9
			GLASGOW CITY LIMITS											
30	9	US 10S	FAS 273	4.8	2055	3	4		7	5		6200	11200	1.9
			FAP 47-MONT. 48											

CO. NO.	SEC. NO.	ROUTE NO.	SECTION DESCRIPTION	SECTION LENGTH	AVERAGE DAILY TRAFFIC	NO. OF ACCIDENTS				NO. OF PEOPLE		AMOUNT OF PROPERTY DAMAGE	TOTAL ECONOMIC LOSS	ACCI-DENT RATE
						PROPERTY DAMAGE	INJURY	FATAL	TOTAL ACCIDENT	INJURED	KILLED			
3	13	US 10	FAS 303	4.6	1842	5	1		6	1		3730	4730	1.9
			FAS 303											
38	10	US 89	GLACIER CO. LINE	21.6	399	5	1		6	1		3500	4500	1.9
			FAP 1-US2											
10	10	US 310	FROMBERG CITY LIMITS	9.6	1226	4	4		8	5		3830	8830	1.9
			FAP 28-US12											
13	5	US 93	DARBY CITY LIMITS	13.3	1085	7	3		10	5		7720	12720	1.9
			FAP 35-MONT. 38											
25	6	MO 34	SHERIDAN CITY LIMITS	8.0	703	2	2		4	3		2170	5170	1.9
			TWIN BRIDGES CITY LIMITS											
13	1	MO 38	FAP 7-US93	8.4	171	1			1			190	190	1.9
			BITTERROOT NATL. FOREST											
9	1	MO 8	POWDER RIVER CO. LINE	39.5	224	5	1		6	2		28720	30720	1.9
			FAP 23-US212											
30	13	MO 43	DEERLODGE CO. LINE	12.5	114		1		1	2		200	2200	1.9
			FAS 274											
30	7	US 10S	FAS 275	3.3	1409	2	1		3	2		1400	3400	1.8
			FAP 19-US10A											
51	2	US 10S	FAP 29-MONT. 41	8.3	1478	7	1		8	1		4980	5980	1.8
			FAS 401											
49	3	US 10	LIVINGSTON CITY LIMITS	5.1	2652	6	2	1	9	2	5	4930	116930	1.8
			FAP 11-US89											

CO. NO.	SEC. NO.	ROUTE NO.	SECTION DESCRIPTION	SECTION LENGTH	AVERAGE DAILY TRAFFIC	NO. OF ACCIDENTS				NO. OF PEOPLE		AMOUNT OF PROPERTY DAMAGE	TOTAL ECONOMIC LOSS	ACCI-DENT RATE
						PROPERTY DAMAGE	INJURY	FATAL	TOTAL ACCIDENT	INJURED	KILLED			
7	13	US 93	KALISPELL CITY LIMITS	11.9	1178	5	4		9	6	2260	8260	1.8	
			FAP 38-MONT. 40											
47	4	US 89	FAP 14-MONT. 6	8.2	763	4			4		730	730	1.8	
			WHITE SUL.SPGS.CITY LIMIT											
41	4	MO 18	CIRCLE CITY LIMITS	10.2	441	2	1		3	2	1980	3980	1.8	
			DAWSON CO. LINE											
52	3	US 10	WIBAUX CITY LIMITS	7.7	980	2	3		5	3	1950	4950	1.8	
			MONTANA-N.D. LINE											
23	11	US 87	TOWN OF KLEIN	3.0	1490	2	1		3	1	1960	2960	1.8	
			FAP 14-MONT. 6											
23	12	US 87	ROUNDUP CITY LIMITS	19.6	546	3	4		7	6	3360	9360	1.8	
			FAS 244											
45	1	US 10	PRAIRIE COUNTY LINE	13.1	1048	9			9		2630	2630	1.8	
			TERRY CITY LIMITS											
29	8	MO 22	ROSEBUD CO. LINE	18.0	165	1	1		2	2	990	2990	1.8	
			GARFIELD CO. LINE											
28	1	MO 20	POWELL CO. LINE	29.8	254	3	2		5	3	1650	4650	1.8	
			LEWIS & CLARK CO. LINE											
5	17	MO 20	FAS 279	26.0	238	4			4		3030	3030	1.8	
			FAP 9-MONT. 33											
2	23	US 87	GREAT FALLS CITY LIMITS	1.4	3335	2	1		3	1	1200	2200	1.8	
			FAP 10-US87											

CO. NO.	SEC NO.	ROUTE NO.	SECTION DESCRIPTION	SECTION LENGTH	AVERAGE DAILY TRAFFIC	NO. OF ACCIDENTS				NO. OF PEOPLE		AMOUNT OF PROPERTY DAMAGE	TOTAL ECONOMIC LOSS	ACCI-DENT RATE
						PROPERTY DAMAGE	INJURY	FATAL	TOTAL ACCIDENT	INJURED	KILLED			
18	3	MO 43	BEAVERHEAD CO. LINE	15.2	201	2			2			640	640	1.8
			SILVER BOW CO. LINE											
7	6	US 2	FAP 52-MONT. 35	10.1	1442	4	4	1	9	8	1	4390	34390	1.7
			FAP 38-MONT. 40											
17	12	US 2	FAS 327 NEAR BAINVILLE	8.2	767	3	1		4	1		3850	4850	1.7
			MONT.-NORTH DAKOTA LINE											
4	1	US 10	MISSOULA COUNTY LINE	12.8	1627	7	6		13	7		7010	14010	1.7
			FAS 263											
4	3	US 10	FAP 5-US93	7.0	4215	11	6	1	18	10	1	8770	40770	1.7
			MISSOULA CITY LIMITS											
46	3	US 10	DRUMMOND CITY LIMITS	1.4	2290	2			2			1560	1560	1.7
			FAS 271											
30	8	US 10S	FAP 47-MONT. 48	4.4	1430	3		1	4	1	1	1170	24170	1.7
			FAS 275											
3	3	US 310	YELLOWSTONE CO. LINE	3.3	2470	3	2		5	3		5100	8100	1.7
			LAUREL CITY LIMITS											
15	15	US 93	POLSON CITY LIMITS	16.6	587	3	3		6	3		1600	4600	1.7
			FAP 36-MONT. 28											
25	16	MO 1	FAS 283	5.3	313		1		1	1		400	1400	1.7
			GALLATIN CO. LINE											
55	4	US 87	PETROLEUM CO. LINE	4.9	331	1			1			300	300	1.7
			FERGUS CO. LINE											

CO. NO.	SEC. NO.	ROUTE NO.	SECTION DESCRIPTION	SECTION LENGTH	AVERAGE DAILY TRAFFIC	NO. OF ACCIDENTS				NO. OF PEOPLE		AMOUNT OF PROPERTY DAMAGE	TOTAL ECONOMIC LOSS	ACCI-DENT RATE
						PROPERTY DAMAGE	INJURY	FATAL	TOTAL ACCIDENT	INJURED	KILLED			
14	7	US 212	MILES CITY CITY LIMITS	11.2	567	3	1		4	6	2040	8040	1.7	
			FAS 332											
53	5	MO 3	GOLDEN VALLEY CO. LINE	11.1	567	2	2		4	4	4770	8770	1.7	
			LAVINA CITY LIMITS											
17	11	US 2	CULBERTSON CITY LIMITS	14.0	880	5	1	1	7	2	8300	54300	1.6	
			FAS 327 NEAR BAINVILLE											
			FAS 304											
3	12	US 10	FAS 303	4.9	2112	2	4		6	7	10300	17300	1.6	
			TREASURE CO. LINE											
33	1	US 10	FAS 311	13.3	1132	5	3	1	9	7	5720	56720	1.6	
			FAS 312											
33	3	US 10	ROSEBUD CO. LINE	10.5	1136	6	1		7	1	2600	3600	1.6	
			FAP 49-MONT. 41											
18	9	US 91	MADISON CO. LINE	22.5	833	10	1		11	1	5710	6710	1.6	
			FAP 36-MONT. 28											
15	16	US 93	FAS 352	5.6	616	1	1		2	1	180	1180	1.6	
			FAS 269											
13	10	US 93	MISSOULA CO. LINE	10.0	1190	5	1	1	7	2	2820	26820	1.6	
			TOWN OF EDWARDS											
50	2	MO 18	FAP 18-MONT. 22	23.5	299	3	1		4	2	1300	3300	1.6	
			FAP 2-US10											
3	19	US 87	MUSSELSHELL CO. LINE	20.4	683	5	3		8	4	4750	8750	1.6	

CO. NO.	SEC. NO.	ROUTE NO.	SECTION DESCRIPTION	SECTION LENGTH	AVERAGE DAILY TRAFFIC	NO. OF ACCIDENTS				NO. OF PEOPLE		AMOUNT OF PROPERTY DAMAGE	TOTAL ECONOMIC LOSS	ACCI-DENT RATE
						PROPERTY DAMAGE	INJURY	FATAL	TOTAL ACCIDENT	INJURED	KILLED			
45	4	US 10	FAS 253	14.6	1037	7	1	1	9	1	1	4400	27400	1.6
			DAWSON CO. LINE											
			SUNBURST CITY LIMITS											
21	8	US 91	FAS 214	7.7	682	2	1		3	1		1800	2800	1.6
			FAP 48-MONT. 47											
3	16	US 10	TREASURE CO. LINE	3.4	1081	1	1		2	2		470	2470	1.5
			FAS 207 & FAS 317											
7	12	US 93	KALISPELL CITY LIMITS	1.8	3116	2	1		3	1		440	1440	1.5
			ROSEBUD CO. LINE											
29	1	MO 6	TOWN OF SUMATRA	13.6	269	2			2			780	780	1.5
			FAS 230											
36	2	US 87	HOBSON CITY LIMITS	22.0	844	6	4		10	7		5150	12150	1.5
			FAP 2-US12											
14	9	US 10	PRAIRIE COUNTY LINE	22.3	1155	9	3	2	14	7	2	23190	74190	1.5
			SIDNEY CITY LIMITS											
27	7	MO 23N	FAIRVIEW CITY LIMITS	10.0	1502	7	1		8	1		1370	2370	1.5
			SHELBY CITY LIMITS											
21	5	US 91	FAS 215 & 410	15.8	1050	9			9			3200	3200	1.5
			MEDICINE LAKE CITY LIMITS											
34	7	MO 16	ROOSEVELT CO. LINE	7.5	500	1	1		2	1		1300	2300	1.5
			FROID CITY LIMITS											
17	14	MO 16	CULBERTSON CITY LIMITS	13.3	708	4	1		5	1		2650	3650	1.5

CO. NO.	SEC. NO.	ROUTE NO.	SECTION DESCRIPTION	SECTION LENGTH	AVERAGE DAILY TRAFFIC	NO. OF ACCIDENTS				NO. OF PEOPLE		AMOUNT OF PROPERTY DAMAGE	TOTAL ECONOMIC LOSS	ACCI-DENT RATE
						PROPERTY DAMAGE	INJURY	FATAL	TOTAL ACCIDENT	INJURED	KILLED			
51	9	MO 41	JEFFERSON CO. LINE FAP 2-US10	5.8	311	1			1		700	700	1.5	
8	11	MO 19	FERGUS CO. LINE FAP 15-US87	3.2	581		1		1	1	2300	3300	1.5	
3	22	MO 3	FAS 318 FAS 328	15.6	707	6			6		3960	3960	1.5	
12	3	US 2	FAP 10-US87 HAVRE CITY LIMITS	2.5	2397	3			3		1570	1570	1.4	
12	5	US 2	HAVRE CITY LIMITS BLAINE CO. LINE	8.0	1932	4	3	1	8	4	10180	36180	1.4	
24	1	US 2	BLAINE CO. LINE CHINOOK CITY LIMITS	12.6	1548	6	4		10	6	12900	18900	1.4	
28	2	US 10S	POWELL COUNTY LINE FAP 8-US10N	14.0	2148	12	3		15	6	16590	22590	1.4	
6	2	US 10	GALLATIN CO. LINE THREE FORKS CITY LIMITS	2.2	1756	2			2		830	830	1.4	
38	14	US 89	FAP 39-MONT. 17 MONT.-CANADA LINE	6.3	317	1			1		150	150	1.4	
10	11	US 310	FAP 28-US12 YELLOWSTONE CO. LINE	8.1	1918	6	2		8	3	2790	5790	1.4	
31	2	MO 33	FAS 408 CHOTEAU CITY LIMITS	19.2	307	1	2		3	4	1180	5180	1.4	

CO. NO.	SEC. NO.	ROUTE NO.	SECTION DESCRIPTION	SECTION LENGTH	AVERAGE DAILY TRAFFIC	NO. OF ACCIDENTS				NO. OF PEOPLE		AMOUNT OF PROPERTY DAMAGE	TOTAL ECONOMIC LOSS	ACCI-DENT RATE
						PROPERTY DAMAGE	INJURY	FATAL	TOTAL ACCIDENT	INJURED	KILLED			
49	10	US 89	CLYDE PARK CITY LIMITS	8.2	491	2			2			1670	1670	1.4
			FAS 339											
			TETON CO. LINE											
31	9	US 91	FAS 221 & 379	10.8	1078	4	1	1	6	3	1	2160	27160	1.4
			FAS 201											
27	9	MO 16	SIDNEY CITY LIMITS	12.4	627	3	1		4	4		1880	5880	1.4
			TOWN OF BUSBY											
22	6	MO 8	ROSEBUD CO. LINE	13.5	291	1	1		2	1		550	1550	1.4
			SHELBY CITY LIMITS											
21	3	US 2	LIBERTY CO. LINE	26.9	860	6	3	2	11	9	2	14190	67190	1.3
			LIBERTY CO. LINE											
48	1	US 2	LIBERTY CO. LINE	12.8	812	3		2	5		2	4850	48850	1.3
			FAS 409											
			FAS 231											
12	2	US 2	FAP 10-US87	37.2	984	13	2	3	18	6	4	13600	107600	1.3
			FAS 251											
17	7	US 2	BROCKTON CITY LIMITS	8.5	958	4			4			1890	1890	1.3
			FAP 13-MONT. 1											
51	7	US 10S	BROADWATER CO. LINE	5.3	1163	3			3			450	450	1.3
			FAP 16-US87											
3	11	US 10	FAS 304	7.6	2452	6	2	1	9	4	1	4810	30810	1.3
			FAS 303											
3	15	US 10	FAP 48-MONT. 47	25.2	1196	13	1		14	1		3800	4800	1.3

CO. NO.	SEC. NO.	ROUTE NO.	SECTION DESCRIPTION	SECTION LENGTH	AVERAGE DAILY TRAFFIC	NO. OF ACCIDENTS				NO. OF PEOPLE		AMOUNT OF PROPERTY DAMAGE	TOTAL ECONOMIC LOSS	ACCI-DENT RATE
						PROPERTY DAMAGE	INJURY	FATAL	TOTAL ACCIDENT	INJURED	KILLED			
35	2	US 10A	FAS 202 TOWN OF TROUTCREEK	18.4	1262	9	2		11	2	4610	6610	1.3	
13	6	US 93	FAP 35-MONT. 38 HAMILTON CITY LIMITS	2.1	1987	2			2		470	470	1.3	
5	2	US 10N	FAS 356 HELENA CITY LIMITS	1.3	3243	1	1		2	2	650	2650	1.3	
19	6	US 87	BIG SANDY CITY LIMITS HILL CO. LINE	9.4	665		3		3	5	4500	9500	1.3	
6	15	US 191	FAP 12-US20 & 191 FAP 50-US191	8.3	741	1	2		3	4	1900	5900	1.3	
47	3	MO 6	MEAGHER CO. LINE FAP 11-US89	10.0	416	1	1		2	1	950	1950	1.3	
47	8	MO 6	FAP 11-US89 FAS 294	31.2	396	3	2	1	6	8	6130	36130	1.3	
53	1	MO 6	GOLDEN VALLEY CO. LINE RYEGATE CITY LIMITS	6.9	628	2			2		850	850	1.3	
29	3	MO 6	TOWN OF INGOMAR FORSYTH CITY LIMITS	40.7	262	4	1		5	1	1030	2030	1.3	
2	18	US 91	FAP 3-US89 TETON CO. LINE	10.8	1340	5	2		7	4	3050	7050	1.3	
41	7	MO 13	FAS 201 ROOSEVELT CO. LINE	12.1	538	1	1	1	3	1	2390	25390	1.3	

CO. NO.	SEC. NO.	ROUTE NO.	SECTION DESCRIPTION	SECTION LENGTH	AVERAGE DAILY TRAFFIC	NO. OF ACCIDENTS				NO. OF PEOPLE		AMOUNT OF PROPERTY DAMAGE	TOTAL ECONOMIC LOSS	ACCI-DENT RATE
						PROPERTY DAMAGE	INJURY	FATAL	TOTAL ACCIDENT	INJURED	KILLED			
8	12	MO 19	LEWISTOWN CITY LIMITS	8.9	916	3	1		4	1		1760	2760	1.3
			FAS 235											
3	6	US 10	SOUTHSIDE BY-PASS	.2	11760	1			1			300	300	1.2
			BILLINGS CITY LIMITS											
3	14	US 10	FAS 303	8.5	1917	3	3	1	7	3	1	1720	26720	1.2
			FAS 303											
1	4		FAP 2-US10S	1.4	3365	2			2			780	780	1.2
			BUTTE CITY LIMITS											
15	13	US 93	FAP 52-MONT. 35	1.3	1754	1			1			140	140	1.2
			POLSON CITY LIMITS											
35	3	US 10A	TOWN OF TROUTCREEK	20.8	960	7	2		9	3		2540	5540	1.2
			THOMPSON FALLS CITY LIMIT											
43	7	MO 6	TOWNSEND CITY LIMITS	22.6	514	4	1		5	1		780	1780	1.2
			MEAGHER CO. LINE											
50	6	MO 22	GARFIELD CO. LINE	45.0	155	3			3			4350	4350	1.2
			FAP 15-MONT. 18											
34	9	MO 16	FAS 258	8.2	543	1	1		2	1		1550	2550	1.2
			MEDICINE LAKE CITY LIMITS											
37	1	MO 13	DANIELS CO. LINE	15.6	289	1	1		2	2		3200	5200	1.2
			SCOBAY CITY LIMITS											
6	18	US 191	YELLOWSTONE PARK BOUNDARY	20.3	337	2	1		3	1		4150	5150	1.2
			YELLOWSTONE PARK BOUNDARY											

CO. NO.	SEC. NO.	ROUTE NO.	SECTION DESCRIPTION	SECTION LENGTH	AVERAGE DAILY TRAFFIC	NO. OF ACCIDENTS				NO. OF PEOPLE		AMOUNT OF PROPERTY DAMAGE	TOTAL ECONOMIC LOSS	ACCI-DENT RATE
						PROPERTY DAMAGE	INJURY	FATAL	TOTAL ACCIDENT	INJURED	KILLED			
38	11	MO 49	FAP 1 NEAR EAST GLACIER	11.9	211	1			1		300	300	1.1	
			FAP 3 NEAR KIOWA											
29	4	US 10	ROSEBUD CO. LINE	9.5	1070	1	3		4	6	1570	7570	1.1	
			FAS 315											
25	4	US 91	MADISON CO. LINE	7.3	661	1	1		2	4	1130	5130	1.1	
			SILVER BOW CO. LINE											
13	9	US 93	FAS 370	7.7	974	1	2		3	3	92100	95100	1.1	
			FAS 269											
43	1	US 10N	BROADWATER CO. LINE	21.0	1149	7	2	1	10	6	1	9000	37000	1.1
			TOWNSEND CITY LIMITS											
44	1	MO 6	WHEATLAND CO. LINE	10.8	452	1	1		2	1	1600	2600	1.1	
			FAS 296											
23	6	MO 6	ROUNDUP CITY LIMITS	22.0	550	4	1		5	1	1750	2750	1.1	
			FAS 310											
16	7	MO 18	TOWN OF LINDSAY	21.5	565	4	1		5	2	2270	4270	1.1	
			FAP 17-US10											
16	9	MO 16	FAS 254	19.4	644	3	2		5	7	2270	9270	1.1	
			RICHLAND CO. LINE											
6	19	US 191	YELLOWSTONE PARK BOUNDARY	24.6	392	1	3		4	4	12750	16750	1.1	
			TOWN OF KARST KAMP											
43	5	US 10S	BROADWATER CO. LINE	4.6	1190	2			2		400	400	1.0	
			FAP 8-US10N											

CO NO.	SEC NO.	ROUTE NO.	SECTION DESCRIPTION	SECTION LENGTH	AVERAGE DAILY TRAFFIC	NO. OF ACCIDENTS				NO. OF PEOPLE		AMOUNT OF PROPERTY DAMAGE	TOTAL ECONOMIC LOSS	ACCI-DENT RATE
						PROPERTY DAMAGE	INJURY	FATAL	TOTAL ACCIDENT	INJURED	KILLED			
39	4	US 12	PLEVNA CITY LIMITS	11.7	713	1		2	3	3	2	2240	49240	1.0
			BAKER CITY LIMITS											
25	12	MO 1	MADISON CO. LINE	36.4	293	3	1		4	1		1050	2050	1.0
			TOWN OF CAMERON											
8	8	MO 18	FAP 16-US87	10.4	275	1			1			400	400	1.0
			PETROLEUM CO. LINE											
50	1	MO 18	GARFIELD CO. LINE	30.2	278	1	2		3	3		2730	5730	1.0
			TOWN OF EDWARDS											
37	3	MO 13	SCOBAY CITY LIMITS	11.1	512	2			2			750	750	1.0
			FAP 31-MONT. 13											
9	8	US 212	POWDER RIVER CO. LINE	25.9	307	3			3			1400	1400	1.0
			FAP 37-MONT. 8											
25	11	MO 34	ENNIS CITY LIMITS	13.0	413	2			2			1670	1670	1.0
			VIRGINIA CITY CITY LIMITS											
8	13	MO 19	FAS 235	5.4	484	1			1			380	380	1.0
			FAS 236											
43	4	US 10N	FAS 285 NEAR TOSTON	21.0	859	4		2	6	3	3	1700	70700	.9
			FAP 2-US10											
22	7	US 87	MONT.-WYOMING STATE LINE	22.6	814	2	4		6	4		16330	20330	.9
			FAS 463 NEAR LODGEGRASS											
14	8	MO 22	MILES CITY CITY LIMITS	19.2	316	2			2			400	400	.9
			ROSEBUD CO. LINE											

CO. NO.	SEC. NO.	ROUTE NO.	SECTION DESCRIPTION	SECTION LENGTH	AVERAGE DAILY TRAFFIC	NO. OF ACCIDENTS				NO. OF PEOPLE		AMOUNT OF PROPERTY DAMAGE	TOTAL ECONOMIC LOSS	ACCI-DENT RATE
						PROPERTY DAMAGE	INJURY	FATAL	TOTAL ACCIDENT	INJURED	KILLED			
26	4	US 91	FAS 365	10.4	1424	3	2		5	4	2520	6520	.9	
			FAS 219											
41	6	MO 13	CIRCLE CITY LIMITS	34.2	439	4	1		5	1	16600	17600	.9	
			FAS 201											
56	9	MO 37	TOWN OF REXFORD	8.0	364	1			1		200	200	.9	
			FAP 5-US93											
40	4	MO 19	BIG TIMBER CITY LIMITS	19.5	303	1	1		2	2	750	2750	.9	
			FAS 371											
30	10	US 10S	DEER LODGE CO. LINE	2.1	1601	1			1		850	850	.8	
			FAS 273											
6	7	US 10	MANHATTAN CITY LIMITS	8.5	1963	2	2	1	5	2	2100	26100	.8	
			BELGRADE CITY LIMITS											
39	6	US 12	BAKER CITY LIMITS	11.7	582	1	1		2	1	1480	2480	.8	
			MONT.-NORTH DAKOTA LINE											
5	7	US 10N	EAST HELENA CITY LIMITS	4.7	1451	1	1		2	1	220	1220	.8	
			JEFFERSON CO. LINE											
16	1	US 10	DAWSON CO. LINE	21.0	1103	6	1		7	1	4620	5620	.8	
			FAP 15-MONT. 18											
26	9	US 91	FAS 216	6.6	1091	1	1		2	1	1170	2170	.8	
			TOOLE CO. LINE											
52	6	MO 7	FAS 413	9.4	357	1			1		300	300	.8	
			WIBAUX CITY LIMITS											

CO. NO.	SEC NO.	ROUTE NO.	SECTION DESCRIPTION	SECTION LENGTH	AVERAGE DAILY TRAFFIC	NO. OF ACCIDENTS				NO. OF PEOPLE		AMOUNT OF PROPERTY DAMAGE	TOTAL ECONOMIC LOSS	ACCI-DENT RATE
						PROPERTY DAMAGE	INJURY	FATAL	TOTAL ACCIDENT	INJURED	KILLED			
8	14	MO 19	FAS 236	20.4	160		1		1	1	100	1100	.8	
			TOWN OF ROY											
3	23	MO 3	FAS 328	13.0	521	1		1	2	1	1	1350	24350	.8
			BROADVIEW CITY LIMITS											
12	1	US 2	HILL CO. LINE	9.3	872	1	1		2	2		3000	5000	.7
			FAS 231											
56	12	US 93	LINCOLN CO. LINE	21.4	390	2			2			1400	1400	.7
			EUREKA CITY LIMITS											
28	3	US 10N	FAP 2-US10	3.6	1121	1			1			300	300	.7
			FAS 407											
25	15	MO 1	FAS 289	10.2	404	1			1			1200	1200	.7
			FAS 283											
19	1	US 87	CHOTEAU CO. LINE	23.1	1105	4	2		6	4		5160	9160	.6
			FAS 386											
35	13	MO 28	HOT SPRINGS SPUR	12.2	390		1		1	1		100	1100	.6
			LAKE CO. LINE											
1	3	US 10S	BREWERY BY PASS	1.1	4600		1		1	1		800	1800	.5
			BUTTE CITY LIMITS											
43	3	US 10N	TOWNSEND CITY LIMITS	10.4	973	1	1		2	2		750	2750	.5
			FAS 285 NEAR TOSTON											
2	26	US 87	FAS 225	10.3	1092	1		1	2	1	6	15600	148600	.5
			CHOTEAU CO. LINE											

CO. NO.	SEC. NO.	ROUTE NO.	SECTION DESCRIPTION	SECTION LENGTH	AVERAGE DAILY TRAFFIC	NO. OF ACCIDENTS				NO. OF PEOPLE		AMOUNT OF PROPERTY DAMAGE	TOTAL ECONOMIC LOSS	ACCI-DENT RATE
						PROPERTY DAMAGE	INJURY	FATAL	TOTAL ACCIDENT	INJURED	KILLED			
26	3	US 91	PONDERA CO. LINE	4.5	1236		1		1	1		18000	19000	.5
			FAS 365											
27	2	MO 23	CO. RD. TO LAMBERT	21.7	271	1			1			70	70	.5
			FAP 20-MONT. 16											
11	3	US 2	DODSON CITY LIMITS	8.1	885	1			1			150	150	.4
			FAS 363											
55	3	MO 18	WINNETT CITY LIMITS	21.7	317	1			1			600	600	.4
			GARFIELD CO. LINE											
52	1	US 10	WIBAUX CO. LINE	6.5	960	1			1			70	70	.4
			WIBAUX CITY LIMITS											
31	11	US 91	FAS 221 & 379	11.0	1260	2			2			1450	1450	.4
			PONDERA CO. LINE											
51	5	US 10S	WHITEHALL CITY LIMITS	5.4	1476		1		1	2		1750	3750	.3
			FAS 281											
25	14	MO 1	ENNIS CITY LIMITS	16.1	541	1			1			140	140	.3
			FAS 289											
48	2	US 2	FAS 409	2.0	1105				NONE					
			CHESTER CITY LIMITS											
24	3	US 2	CHINOOK CITY LIMITS	.5	1836				NONE					
			FAS 325											
7	25		FAP 1 NEAR WEST GLACIER	.3	690				NONE					
			GLACIER PARK BOUNDARY											

CO. NO.	SEC NO.	ROUTE NO.	SECTION DESCRIPTION	SECTION LENGTH	AVERAGE DAILY TRAFFIC	NO. OF ACCIDENTS				NO. OF PEOPLE		AMOUNT OF PROPERTY DAMAGE	TOTAL ECONOMIC LOSS	ACCI-DENT RATE
						PROPERTY DAMAGE	INJURY	FATAL	TOTAL ACCIDENT	INJURED	KILLED			
28	9	US 10S	FAP 8-US10N	4.8	1626				NONE					
			FAS 407											
33	2	US 10	FAS 311	5.0	1304				NONE					
			FAS 312											
3	7		FAP 2 WEST OF BILLINGS	.3	9012				NONE					
			BILLINGS CITY LIMITS											
3			BILLINGS CITY LIMITS	.6	2220				NONE					
			FAP 2 EAST OF BILLINGS											
31	8	US 89	FAS 219	5.6	227				NONE					
			PONDERA CO. LINE											
4	11		FAP 7 SOUTH OF MISSOULA	.2	4250				NONE					
			MISSOULA CITY LIMITS											
51	13	US 10N	JEFFERSON CO. LINE	1.5	1354				NONE					
			BROADWATER CO. LINE											
2	24	US 87	GREAT FALLS CITY LIMITS	.4	6070				NONE					
			FAP 40											
19	2	US 87	FAS 386	1.6	602				NONE					
			FAS 223 & 230											
49	5	US 89	YELLOWSTONE PARK	.5	943				NONE					
			GARDINER											
49	8	US 89	FAP 2-US10	14.3	664				NONE					
			CLYDE PARK CITY LIMITS											

CO. NO.	SEC. NO.	ROUTE NO.	SECTION DESCRIPTION	SECTION LENGTH	AVERAGE DAILY TRAFFIC	NO. OF ACCIDENTS				NO. OF PEOPLE		AMOUNT OF PROPERTY DAMAGE	TOTAL ECONOMIC LOSS	ACCI-DENT RATE
						PROPERTY DAMAGE	INJURY	FATAL	TOTAL ACCIDENT	INJURED	KILLED			
47	6	US 89	WHITE SUL.SPGS.CITY LIMIT	2.1	664				NONE					
			FAP 14-MONT. 6											
2	27	US 89	AIR BASE ROAD	1.1	6200				NONE					
			GREAT FALLS CITY LIMITS											
44	7	MO 6	FAS 297	.1	701				NONE					
			FAS 394											
23	2	MO 6	FAS 381	4.9	466				NONE					
			FAP 16-US87											
23	7	MO 6	FAS 310	11.5	486				NONE					
			MELSTONE CITY LIMITS											
23	9	MO 6	MELSTONE CITY LIMITS	2.0	413				NONE					
			ROSEBUD CO. LINE											
50	3	MO 18	FAP 18-MONT. 22	.2	538				NONE					
			JORDAN CITY LIMITS											
8	4		FAP 15-US87	2.5	546				NONE					
			LEWISTOWN CITY LIMITS											
8	18	MO 19	FAP 15-MONT. 18	21.0	35				NONE					
			FAP 43-MONT. 19											
45	3	US 10	TERRY CITY LIMITS	.1	1598				NONE					
			FAS 253											
46	9	US 10A	ROAD TO PHILIPSBURG	.4	461				NONE					
			FAS 348											

CO. NO.	SEC. NO.	ROUTE NO.	SECTION DESCRIPTION	SECTION LENGTH	AVERAGE DAILY TRAFFIC	NO. OF ACCIDENTS				NO. OF PEOPLE		AMOUNT OF PROPERTY DAMAGE	TOTAL ECONOMIC LOSS	ACCIDENT RATE
						PROPERTY DAMAGE	INJURY	FATAL	TOTAL ACCIDENT	INJURED	KILLED			
27		MO 23N	FAIRVIEW CITY LIMITS	.3	262				NONE					
			MONT. N.DAK. LINE											
21	9	US 91	FAS 214	.1	577				NONE					
			MONTANA-CANADA LINE											
37	4	MO 5	FAP 31-MONT. 13	6.5	302				NONE					
			SHERIDAN CO. LINE											
34	4	MO 5	PLENTYWOOD CITY LIMITS	1.0	1107				NONE					
			FAP 30-MONT. 5											
9	2	US 212	FAP 37-MONT. 8	2.7	570				NONE					
			FAS 391											
9	6	US 212	FAS 402	1.9	386				NONE					
			FAS 319											
17	18	MO 13	ROOSEVELT CO. LINE	.4	817				NONE					
			FAP 32-MONT. 13											
52	4	MO 7	WIBAUX CO. LINE	1.0	210				NONE					
			FAS 413											
52	5	MO 7	FAS 413	14.0	223				NONE					
			FAS 413											
25	1	MO 41	FAS 401	1.1	295				NONE					
			SILVER BOW CO. LINE											
1	11	MO 41	SILVER BOW CO. LINE	1.5	295				NONE					
			JEFFERSON CO. LINE											

CO. NO.	SEC. NO.	ROUTE NO.	SECTION DESCRIPTION	SECTION LENGTH	AVERAGE DAILY TRAFFIC	NO. OF ACCIDENTS				NO. OF PEOPLE		AMOUNT OF PROPERTY DAMAGE	TOTAL ECONOMIC LOSS	ACCI-DENT RATE
						PROPERTY DAMAGE	INJURY	FATAL	TOTAL ACCIDENT	INJURED	KILLED			
37	6	MO 13	TOWN OF WHITETAIL	7.3	96				NONE					
			MONTANA-CANADA LINE											
17	19	MO 13	FAP 25-MONT. 13W.	4.1	136				NONE					
			FAP 1-US2											
15	1	MO 28	LAKE CO. LINE	.5	280				NONE					
			FLATHEAD CO. LINE											
35	12		FAP 36-MONT. 28	1.7	863				NONE					
			HOT SPRINGS CITY LIMITS											
38	15	MO 17	FAP 3-US89	14.3	131				NONE					
			MONTANA-CANADA LINE											
2	5	US 87	FAP 11-US89	1.2	5335				NONE					
			GREAT FALLS CITY LIMITS											
41	8	MO 24	BEGIN STATE CONSTRUCTION	24.5	47				NONE					
			VALLEY CO. LINE											
44	12	MO 19	JUDITH GAP CITY LIMITS	.7	570				NONE					
			FERGUS COUNTY LINE											
8	9	MO 19	FERGUS COUNTY LINE	3.0	575				NONE					
			JUDITH BASIN CO. LINE											
36	5	MO 19	JUDITH BASIN CO. LINE	.7	580				NONE					
			FERGUS CO. LINE											
8	10	MO 19	FERGUS CO. LINE	10.5	534				NONE					
			JUDITH BASIN CO. LINE											

CO. NO.	SEC. NO.	ROUTE NO.	SECTION DESCRIPTION	SECTION LENGTH	AVERAGE DAILY TRAFFIC	NO. OF ACCIDENTS				NO. OF PEOPLE		AMOUNT OF PROPERTY DAMAGE	TOTAL ECONOMIC LOSS	ACCI-DENT RATE
						PROPERTY DAMAGE	INJURY	FATAL	TOTAL ACCIDENT	INJURED	KILLED			
36	6	MO 19	JUDITH BASIN CO. LINE	2.9	541				NONE					
			FERGUS CO. LINE											
18	1	MO 43	MONTANA-IDAHO LINE	24.6	53				NONE					
			FAS 278											
30	14	MO 43	FAS 274	2.5	157				NONE					
			SILVER BOW CO. LINE											
1	7	MO 43	SILVER BOW CO. LINE	1.7	170				NONE					
			BEAVERHEAD CO. LINE											
3	17	MO 47	YELLOWSTONE CO. LINE	6.9	157				NONE					
			FAP 2-US10											
16	11	MO 23	FAS 254 & 468	4.7	58				NONE					
			RICHLAND CO. LINE											
3	20	MO 3	BILLINGS CITY LIMITS	.1	5550				NONE					
			FAS 302											
3	21	MO 3	FAS 302	.8	3120				NONE					
			FAS 318											
53	6	MO 3	LAVINA CITY LIMITS	.4	666				NONE					
			FAP 14											

